



Steiner
Ranch™

**RESIDENTIAL DESIGN
GUIDELINE MANUAL**

January 1, 2010



Table of Contents

| | |
|--|------------|
| 1. Introduction | 3 |
| 2. Purpose | 4 |
| 2.1 Preface | 5 |
| 2.2 Definitions | 7 |
| 3. Policies & Procedures | 10 |
| 3.1 Submittal Requirements | 12 |
| 3.2 Approval Process | 15 |
| 3.3 Owner/Builder Responsibilities | 19 |
| 3.4 Construction Inspections | 23 |
| 4. Site Construction | 26 |
| 4.1 Construction Site Management | 27 |
| 4.2 Preserving & Protecting the Environment | 29 |
| 5. Building/Site Relationship | 31 |
| 5.1 Building Setbacks | 32 |
| 5.2 Impervious Cover | 34 |
| 5.3 Building Orientation | 35 |
| 5.4 Grading & Drainage | 37 |
| 6. Architectural Guidelines | 38 |
| 6.1 Façade Design | 39 |
| 6.2 Foundations | 42 |
| 6.3 Height Limits | 44 |
| 6.4 Roofs | 45 |
| 6.5 Chimneys | 47 |
| 6.6 Garages | 48 |
| 6.7 Energy Saving Features | 50 |
| 7. Site Details | 51 |
| 7.1 Driveways & Parking | 52 |
| 7.2 Sidewalks & Entry Walks | 54 |
| 7.3 Retaining Walls | 56 |
| 7.4 Screening | 58 |
| 7.5 Fences & Freestanding Walls | 60 |
| 7.6 Site Lighting | 63 |
| 7.7 Accessory Structures | 64 |
| 7.8 Wood Decks | 69 |
| 7.9 Greenbelts | 70 |
| 8. Landscape Guidelines | 71 |
| 8.1 Landscape Design | 72 |
| 8.2 Installation & Maintenance | 76 |
| 8.3 Integrated Pest Management | 78 |
| 8.4 Approved Plant List | 80 |
| 9. Signage Guidelines | 88 |
| 10. Wildland Urban Interface (WUI) Guidelines | 100 |
| 11. Appendix | 104 |
| Fine/Fee List | 105 |
| Sample Forms | |
| Controlling Common Household Pests Safely | |
| Selected City of Austin Construction Standards | |

1. Introduction

The Setting:

Steiner Ranch is located in the gently rolling hills on the edge of the Texas Hill Country, with four and a half miles of Lake Austin frontage, and within a stone's throw from Lake Travis.

It is this delightful setting and its close proximity to major Northwest Austin area employers that make Steiner Ranch an attractive master planned community.

Goals:

The Residential Design Guidelines presented here are intended to promote a high and consistent development standard. It is the goal of the Developer (the “*Declarant*”) and the Architectural Committee (the “*AC*”), with authority as delegated, to retain and enhance the Hill Country’s natural and cultural character on Steiner Ranch.

Each residential *unit* in Steiner Ranch is the result of years of intensive and careful planning. These *owner/builder* requirements and guidelines establish a continuum between the Developer’s past planning efforts and the future homeowner’s pride in his or her *residence*. Standards, which promote these high qualities, benefit

everyone involved with Steiner Ranch.

In addition to describing general policies and procedures, these guidelines cover six different aspects of the residential construction process:

-  Site Construction
-  Building/Site Relationship
-  Architectural Guidelines
-  Site Details
-  Landscape Guidelines
-  Signage Guidelines

Applicability:

This Design Guideline Manual applies to all residential *improvements*, whether the construction is for a new home or remodeling and/or additions to an existing home.

The *AC* will review all proposed construction plans for compliance with the established regulations/guidelines contained herein.

It is recognized that the design review for different architectural designs and the character of each individual and unique home-site is an interactive and dynamic process.

Modifications to this Manual may be made from time to time to clarify or expand the requirements and guidelines to maintain the overall goals

established for Steiner Ranch.

After you have reviewed these Regulations, please contact the Architectural Control Committee at the designated address or phone number, should you need more information about the policies or procedures for administration of this Manual.

2. Purpose

The regulations and guidelines described in this Manual provide guidance to *builders* and residents in the development of Steiner Ranch residential building sites.

The development of each *unit* within Steiner Ranch is controlled and restricted by applicable governmental codes and regulations. In addition, there is the Declaration of Covenants, Conditions, and Restrictions (“Declaration”) for Steiner Ranch residential areas, which apply to all property development within Steiner Ranch. Compliance priority in all cases is with applicable codes and regulations along with the Declaration.

These Design Guidelines are a supplement to the above stated controls. These regulations and guidelines provide practical design direction which, when implemented, will create a high quality residential community environment. The objective of this Manual is to describe the design goals, requirements and guidelines that are common to all Steiner Ranch neighborhoods and to achieve aesthetic compatibility among neighborhoods. **Compliance with the Design Guidelines does not guarantee approval of an application.**

Specific restrictions in the form of Supplemental Declarations will apply to individual neighborhoods. These Supplemental Declarations will supersede any provisions in these Design Guidelines.

Definitions:

Each subject area of the Design Guidelines Manual is structured around the headings of Goals, Requirements, and Guidelines. These are briefly described below:

Goals of the *Declarant* are defined within each subject area. These goals are a product of the Developer’s vision of Steiner Ranch.

This vision has been expressed and refined throughout the planning and design process. At an appropriate time in the future, the *Declarant* will pass on the responsibility of determining the design criteria to the *Association* and its Board, through the Architectural Control Committee.

Requirements described in this Design Guideline Manual are essential conditions of development and are enforced by the *Association*.

Guidelines described in this manual are recommended

criteria, which reinforce the character of Steiner Ranch.

The organization of this manual should provide a reference framework for new residential construction, remodeling, and additions alike.

Sections:

- 2.1 Preface
- 2.2 Definitions

2.1 Preface

The developer is developing a master planned community generally known as Steiner Ranch. The residential property is being developed in phases some or all of which may be annexed and made subject to the Declaration of Covenants, Conditions and Restrictions for Steiner Ranch residential areas (the “Declaration”) which will be recorded as an Instrument of the Official Records of Travis County, Texas.

In addition to any other covenants, conditions and restrictions set forth in the Declaration, Owners and Homebuilders (“owner/builder”) must also comply with all requirements set forth in this manual which has been prepared by the *Declarant* in constructing, modifying and maintaining any *improvements* upon their property.

This Manual (hereinafter the “Regulations”) adopted by the *AC* on the date indicated on the cover page will be in effect until additions or modifications are adopted by the *Declarant* pursuant to the Declaration.

Owners/builders must become familiar with all provisions of the Declaration, as well as the Regulations. Pursuant to the Declaration, no *improvements* are to be made except in compliance with the provisions of the Declaration and the Regulations. In addition, all *improvements* are to be maintained in good condition and repair in accordance with the provisions of the Declaration and the Regulations. The *Association* shall have all of the remedies available under the Declaration and Regulations, including the rights set forth in the Bylaws.

As set forth in the Declaration, the plans and specifications submitted for review are **not** being reviewed for structural integrity; compliance with zoning and building ordinances or any other applicable statutes; ordinances or governmental rules or regulations; compliance with the requirements of any public utility, easement or other agreement; or preservation of any view.

By approving such plans and specifications, neither the *Declarant*, the *Association*, the owners, the Board nor any committee member, nor agents, employees, attorneys, or consultants of any of the foregoing shall be liable for any soil conditions, drainage or general site work, nor for any injury, damages or loss arising out of the manner or quality of approved construction or modification on account of such approved plans or specifications, nor for an impairment of view as a result of such approval.

The *AC* will review plans and specifications submitted for its approval as to style, exterior design, appearance and location, and will approve such plans and specifications only if it determines, in its sole discretion, that the *improvements* will not be detrimental to the appearance of the development as a whole, that the *improvements* comply with the Regulations, that the appearance will be in harmony with the surrounding structures, that the construction will not

2.1 Preface

detract from the beauty and attractiveness of the development or the enjoyment by owners and that the upkeep and maintenance will not become a burden on the *Association*.

The *Association* is empowered to take disciplinary action against any *owner/builder* for a violation of any provision in these Regulations.

2.2 Definitions

For convenience and to reduce the potential for misunderstandings, many of the terms used within this Manual are taken from the Declaration. These terms and others will be found throughout the Manual in **italic type**, so that reference may be made to the following section for definition.

Architectural Committee

“*Architectural Committee* (“AC”)” shall mean the committee created pursuant to this Declaration to review and approve plans for the construction of *improvements* upon the property.

Builder

“*Builder*” shall mean any person who purchases one or more *units* for the purpose of constructing *improvements* for later sale to consumers, or who purchases one or more parcels of land within the Properties for further subdivision, development, and/or resale in the ordinary course of such Person’s business.

Building Permit

“*Building permit*” shall mean a permit issued by Travis County, Texas or any governmental jurisdiction as necessary for the construction of any *improvements* on a *unit*.

Community Association

“*Community Association*” shall mean Steiner Ranch Master Association, Inc., Texas nonprofit corporations, their successors and/or assigns.

Condominium

“*Condominium*” means a form of real property with portions of the real property designated for separate ownership or occupancy and the remainder of the real property designated for common ownership or occupancy solely by the owners of those portions. Real property is a condominium only if one or more of the common elements are directly owned in undivided interests by the unit owners. Real property is not a condominium if all of the common elements are owned by a legal entity separate from the unit owners, such as a corporation, even if the separate legal entity is owned by the unit owners.

Declarant

“*Declarant*” shall mean Taylor Woodrow Communities/Steiner Ranch, Ltd., a Texas limited partnership or any successor or assign who takes title to any portion of the property for the purpose of

development and/or sale and who is designated as the *Declarant* in a recorded instrument executed by the immediately preceding *Declarant*.

Exclusive Common Area

“*Exclusive Common Area*” shall mean a portion of the Common Area primarily benefiting one or more, but less than all, Neighborhoods.

Improvement

“*Improvement*” shall mean structures and appurtenances thereto of every type and kind; the demolition or destruction by voluntary action of any such structure or appurtenance thereto; any grading, excavation, filling, or similar disturbance of the surface of the land; landscaping, planting and clearing, or removing of trees, shrubs, grass, or foliage; and any change or alteration of any *residence* including change of material, exterior appearance, color or texture (ex. pools, outbuildings, patios, decks, etc.).

Lot

“*Lot*” shall mean the legally defined land by plat. It may refer to a single family residence or the combined area for a condominium unit.

2.2 Definitions

Masonry

“*Masonry*” shall mean a brick or stone veneer product installed with mortar joints.

Maintenance Association

“*Maintenance Association*” shall mean the associations established to maintain condominium projects.

Open Space

“*Open Space*” shall refer to lots that are defined as greenbelt or golf course by plat, parkland, community center lots, or any other land that has not been developed, whether it is owned by the Developer or other property owner.

Owner

“*Owner*” shall mean one or more Persons who hold the record title to any *unit*, but excluding in all cases any party holding an interest merely as security for the performance of an obligation. If a *unit* is sold under a recorded contract of sale and the contract specifically so provides, the purchaser (rather than the fee *owner*) will be considered the *Owner*.

Residence

“*Residence*” shall mean any structures and appurtenances thereto intended as a single family home, and/or condominium residence, which is attached or

detached from other condominium residences.

Stucco

“*Stucco*” will refer to the rough, plaster veneer, typically installed over a wood lathe or wire mesh as the exterior material of a building or other structure.

Unit

“*Unit*” shall mean a portion of the property, whether improved or unimproved, which may be independently owned and is intended for development, use and occupancy as an attached or detached *residence* for a single family. The term shall refer to the land, if any, which is part of the *unit* as well as any *improvements* thereon. In the case of a building within a condominium or other structure containing multiple *residences*, each *residence* shall be deemed to be a separate *unit*, and will include any limited common area as defined in the declaration for that area.

In the case of a parcel of vacant land or land on which *improvements* are under construction, the parcel shall be deemed to contain the number of *units* designated for residential use for such parcel on the land use plan or the site plan approved by *Declarant*, whichever is more recent, until such time

as a preliminary and final plat is filed of record on all or a portion of the parcel.

Thereafter, the portion encompassed by the most recent plat shall contain the number of *units* determined as set forth in the preceding paragraph and any portion not encompassed by such plat shall continue to be treated in accordance with this paragraph.

Quality of Improvements

It is the objective of the Regulation that the *improvements* within Steiner Ranch reflect the established standards. It is the responsibility of the owners to preserve the integrity through the careful development of all of the *improvements* upon the *units*.

- 1) The key elements which reflect the design direction include the following:
 - Quality architecture and landscape architecture design.
 - Simple, elegant, architectural statements.
 - As viewed from all angles, residential harmony between the home, the site and the surrounding development.

2.2 Definitions

- Continuity of architectural forms, materials, textures, colors, and execution.
 - A *residence* reflective of the architectural standards established for Steiner Ranch.
- 2) Each *owner*, by accepting title to his *unit* acknowledges and agrees to the following:
- That the Regulations are reasonable and beneficial to the community.
 - To strive to achieve a spirit of cooperation and resolution between the *AC* and the *owner/builder*, and the *owner's* architect and/or landscape architect.
 - **That the Regulations are not intended to be all encompassing and are meant to encourage creativity while allowing the *AC* wide latitude of approval authority.**

Scope of Review

The regulations are comprised of procedures for the submittal of plans and specifications, the approval procedure, construction requirements, architectural standards, landscape architectural standards, and signage standards.

The purpose of these Regulations is to provide a procedure and establish guidelines and requirements for assisting each *owner/builder* in obtaining approval of construction, landscape design and installation, additions, alterations, or changes to his *Residence* and the *improvements* thereon. Compliance with the Regulations does **not** guarantee approval of an application. Variances may be approved at the discretion of the *AC*. No variance is granted unless specifically stated in writing by the *AC*.

3. Policies & Procedures

Introduction:

These policies and procedures have been adopted by the AC to provide for a standardized review methodology.

General:

Review and approval of any application submittal and/or construction inspection, in accordance with procedures set forth in these Regulations, is made on the basis of aesthetic considerations only. Neither Taylor Woodrow Communities/ Steiner Ranch, Ltd., the Steiner Ranch Residential Owners Association, Inc. (the “*Association*”), the Steiner Ranch Master Association, (the *Association*”), nor its Board, shall bear any responsibility for ensuring the structural integrity or soundness of approved construction or modifications, nor for ensuring compliance with building codes or other governmental requirements.

Neither the Developer, the *Association*, its Board, the AC, nor any member of any of the foregoing shall be held liable for any injury, damage, or loss arising out of the manner or quality of approved construction on or modification to any lot or tract.

Upon submission of a written request, the AC may, in its sole discretion, permit Owners to construct, erect, or install *improvements*, which are in variance from the Guidelines, Restrictions or Declaration, when in its sole and absolute discretion such variance will not be adverse to the overall development plan, and such variance is justified due to visual or aesthetic considerations, or unusual circumstances. All variance approvals must be in writing and signed by a majority of the members of the AC. An approval is based on the individual application and, in no event, does it set a precedent for future applications.

The First Step:

The first step is a design evaluation and analysis of the Regulations and Declaration. Prior to starting any design work, the *owner/builder* and their architect, or home designer, should contact the AC. With advance notice, the AC can provide the *owner/builder* a Design Guidelines Manual, and *unit*-specific information concerning setbacks, utility easements and other restrictions which may be available.

Enforcement & Inspections:

The AC, through the *Association*, is charged with enforcement of the policies, procedures and design requirements of the Manual. Any person who has submitted an application for approval agrees to allow entry onto the land or premises which is the subject of such application for the purpose of inspection as necessary to assure compliance with these Regulations (see Submittal Requirements, Section 3.1). When the AC determines that any policy, procedures, or design requirement has not been complied with, construction will be ordered to cease and desist until corrected by compliance. This cease and desist order may be in the form of an Inspection Report or by separate notice (see Construction Inspections, Section 3.4).

All outstanding approvals will be suspended until construction conditions are brought into compliance. The *Association*'s Board of Directors may authorize bringing suit in a court of competent jurisdiction to restrain and enjoin any person who attempts to carry out any construction without first obtaining approval as required by this Manual or any person who fails to cease and desist from further

3. Policies & Procedures

construction in non-compliance.

Sections:

- 3.1 Submittal Requirements
- 3.2 Approvals
- 3.3 *Owner/Builder*
Responsibilities
- 3.4 Construction Inspections

3.1 Submittal Requirements

General:

The construction or installation of any *improvements*, changes to existing *improvements*, the reconstruction of *improvements*, or the installation or change of exterior ground *improvements* will require the submission of plans and specifications for review and approval of the AC before any such construction or installation activity is commenced. The AC may waive plan and specification requirements for certain modifications or *improvements* at its discretion.

Three submittals are described in this section:

- A. *Builder* Master Architectural Plans
- B. *Builder* Plot Plans
- C. Architectural Modifications

The *owner/builder* making any of these three submittals should carefully review this manual before making a submittal.

The approval process overview is diagrammed on page 17. This overview may assist the reader in understanding how the submittal requirements and the approval process are related for each type of submittal.

Further, the inspection process overview is diagrammed on page 24. This overview illustrates the approval process for:

-  New Units
-  Architectural Modifications

Pre-submittal Review

Although not mandatory, in an effort to expedite the submittal process, the *owner/builder* is encouraged to meet with an AC representative at an early stage for pre-submittal review to address any submittal uncertainties before much time and effort has been spent. This pre-submittal review could be helpful for first-time *owner/builders* going through the submittal process, as well as *owners/builders* addressing unusual design issues. No fee is associated with this review.

Time and effort will be saved with an understanding of the submittal requirements. The AC's representative is available to answer questions and clarify the Regulations' design intent.



A. *Builder* Master Architectural Plans Submittal Requirements:

The *owner/builder* must submit each architectural plan type proposed for construction within Steiner Ranch for approval by the AC.

Once the plans and specifications have been completed, a submittal packet must be submitted to the *Architectural Control Committee* at the designated address. Once a *builder's* master architectural plan is approved, only an individual plot plan, *Masonry* or *Stucco* selection and completed submittal cover sheet are required for each new *unit*.

Any permanent changes to the master plans and/or specifications must be resubmitted for approval.

Submittal Requirements:

-  Executed Submittal Application form.
 -  2 sets of plans. Each consisting of a floor plan, all elevations, and roof plan. Include any standard floor plan options, such as optional game room versus standard bedroom.
- Square footage of plan options is required for approval.

3.1 Submittal Requirements

 2 sets of construction specifications/description of materials, including landscaping.

 1 binder, with color photos, or *Masonry/Stucco* samples or sample books provided by material suppliers. (If requested by AC)

 Building plan name, plan reference number(s), square footage, and *Masonry or Stucco* square footage according to the AC's adopted method of calculation.

 Any other information or documentation deemed necessary by the AC.

B. **C. Builder Plot Plan Submittal Requirements (Single Family Detached Lot):**

After architectural plans have been approved, a plot plan, *Masonry* selection sheet, submittal cover sheet, compliance agreement and a construction deposit are required to be submitted for approval prior to construction on any *unit*.

In the case of major revisions to a previously approved building plan (as defined herein), both

architectural plans and complete specifications in accordance with Part A above must be submitted along with the plot. Major options previously submitted must be noted with additional square footage.

Submittal Requirements:

 2 copies of the completed submittal application form executed by the *builder's* representative (see Appendix for sample).

 2 copies of a plot plan, at 1" = 20'-0" or 1" = 30'-0" scale, with the following building information clearly indicated:

 Location of the *residence* on the lot with dimensions to all property lines.

 Driveway, entry walks, and sidewalk locations and widths.

 Street sidewalks, if required by plat.

 Location **and type** of all fencing.

 Existing topographical lines. Slab elevation, existing and finish grade at corners of *residence*, driveway, and corners of *unit* or lot.

 Location and **finish grade** of any patio or deck.

 Location, height, and material of any retaining wall over 2 feet high.

 Existing trees 8" or greater in diameter (25" circumference). Tree survey required showing any trees over 8" in diameter.

 Building plan name, plan reference number(s), and square footage indicated within the building footprint.

 Plans for foundation screening, per requirements in section 6.2.

 Location of all utility pedestals, transformers, manholes, meter boxes, hydrants and storm sewer inlets

If the building plan has major changes (as defined herein) from a previously approved master architectural plan, please follow the submittal process for Master Plan Submittals noting the changes from originally approved plan.

See Appendix for sample submittal forms.

3.1 Submittal Requirements

Major changes are defined as: changes in the building footprint exceeding two feet in any direction; changes in exterior elevations; changes in building height exceeding one foot per floor; changes in roof pitch from the standard elevation; and any proposed two story decks or decks accessed from the second floor of *residences*.

D. Condominium Attached and Detached Submittal Requirements

Approval for site plan, *condominium* unit design, and other improvements on the defined *condominium* lot. Please see specific submittal requirements for *condominium* units in Section 10. *Condominium* Guidelines.

E. Architectural Modifications Submittal Requirements:

Approval for architectural modifications or alterations to existing *residences* or accessory structures is addressed in this part. Any modifications to a *condominium* residence must first have the written approval of the Maintenance Association, before being

submitted to the *AC* for review.

 The Architectural Modification Application/ Approval form (see Appendix for sample) must be completed and executed by the property *owner* and submitted to the *AC*.

 Any addendum which applies to the specific modification.

The following items must accompany this request.

 A scaled drawing showing plan and elevation views of the proposed *improvements*, modifications or alterations. Submittal must include samples depicting the proposed materials and colors to be used.

 A lot survey (which the *owner* receives at closing) indicating the location of proposed *improvements*, and any applicable easements, setbacks, and elevation differences on lot.
Indicate dimensions to all adjacent property lines.

The *AC* may require the submittal of a certified form survey for any permanent

improvement constructed within one (1) foot of any setback. The survey if required at time of approval must be submitted after forms are set and prior to pouring to continuing construction of the proposed improvements.

Note: It is strongly recommended that the *owner* have a licensed surveyor provide both a topographic and boundary survey.

3.2 Approval Process

General Requirements:

Submittals should be delivered to the AC by mail or in person at the designated address.

If the AC finds a submittal to be in compliance with the provisions of these Regulations, the AC will send an approval letter to the *owner/builder*. The valid approval period begins with the specified date in the letter.

Construction must be completed in accordance with the approved plans within the valid approval period.

If the approved construction or modifications are completed within the allowed approval period, the approved plans are exempt from any future changes in these Regulations.

Note: Special care must be given to all irrigation and landscape previously installed in Common Areas. *Owner/Builder* will be responsible for any damage to the above existing installations damaged during construction or remodeling of his *improvements*.

Approval

AC will give final approval or disapproval of the Application for Approval of Plans and Specifications within thirty (30) days from the date of the submission of a complete application. An application will not be deemed to be complete until all of the documents and information set forth above has been provided to the AC. Failure of the AC to approve plans and specifications within thirty (30) days from the date that a complete application was duly submitted in accordance with all of the requirements of these regulations and guidelines will mean that the plans and specifications will be automatically deemed to be approved.

Upon approval by the AC, one (1) approved copy will be returned to the *owner/builder* who will be responsible for ensuring that the information contained in the approved copy is used in obtaining all required permits and approvals by the City or other government jurisdiction. The second copy will be held on file for (1) year after completion.

Variance

Variances from compliance with certain architectural standards and requirements

may be granted in accordance with the Declaration under certain extenuating circumstances. A request in writing must be submitted to the AC to review for a variance. The exact nature of the variance requested must be outlined in the request. An approval of a variance does not constitute approval of any future requests for the same item. A variance request is not approved, unless specifically stated in writing by the AC.





Government Jurisdiction Approval

Approval by the AC shall not be deemed to be approval by the governing entities.

3.2 Approval Process

Pre-Construction Requirements

After the issuance of any required approval and prior to the delivery of any construction materials or the commencement of any construction, installation or modification activity, the *owner/builder* must deliver to the AC the following:

-  A written notice that all required governmental approvals have been received;
-  Two (2) copies of insurance certificates evidencing that the *Association* is named as an additional insured on the liability insurance policy issued in insuring against loss, damage or injury which may occur as the result of entry and activity by such contractor or its agent, employees, or designees;
-  The anticipated date of commencement of construction. This date must be within one (1) year of the date approval was granted; and
-  Construction deposit placed with applicable Homeowner's *Association* until *residence* passes the final inspection and all associated fines are paid in full. If fines are not

paid, they will be deducted from the deposit.

A diagram is provided at the end of this section (p. 17) illustrating the approval process overview.

A. Builder Master Architectural Approval:

Master plan approvals are valid from the date of acceptance. There is no time limit on the approval, and the master plan may be used for the entire time period the *builder* is building in Steiner Ranch. Although the plan may be used in each of the different sections of Steiner Ranch, a list of **all** master plans must still be supplied to the AC for each section. Master plans must meet minimum requirements of each section's deed restrictions.

Once approved, one set of plans and specifications will be returned to the *builder* for their file. One set will be retained by the AC for reference. Each approved plan will be assigned a building plan number for further reference.

B. Builder Plot Plan Approval:

Approval of plot plans is valid for four (4) months from the date of approval. Commencement of construction must occur within this timeframe or the plan is no longer valid. The plan must be resubmitted for approval after the valid approval period has expired. Completion of initial construction is required within twelve (12) months from the date of Plot Plan approval.

C. Condominium Site Plan Approval:

Approval of site plan is good for six months from the date of the approval from the AC. Commencement of construction must occur within this time frame. The approval is no longer valid after this period and must be resubmitted to begin construction.

Completion of initial construction is required within twenty-four (24) months from date of site plan approval, unless an extension is submitted and approved by the AC.

D. Architectural Modifications Approval:

Approval of construction remodeling and additions is valid for four (4) months from the date of approval. Commencement of construction must occur within this timeframe. The approval is no longer valid after this period.

The AC will determine the required date of completion of additional construction, remodeling, alterations, or additions at the time of approval of the plans and specifications. Such approval and subsequent

time frame will be based upon the type of *improvement* being requested.

In all cases, completion of construction is required within twelve (12) months from the date of approval.

3.2 Approval Process

APPROVAL PROCESS OVERVIEW

The diagrams shown below are schematic only. Refer to text in this section for detail description.

A. Builder Master Architectural Plan Approval Process (Multiple Units/Custom Design)

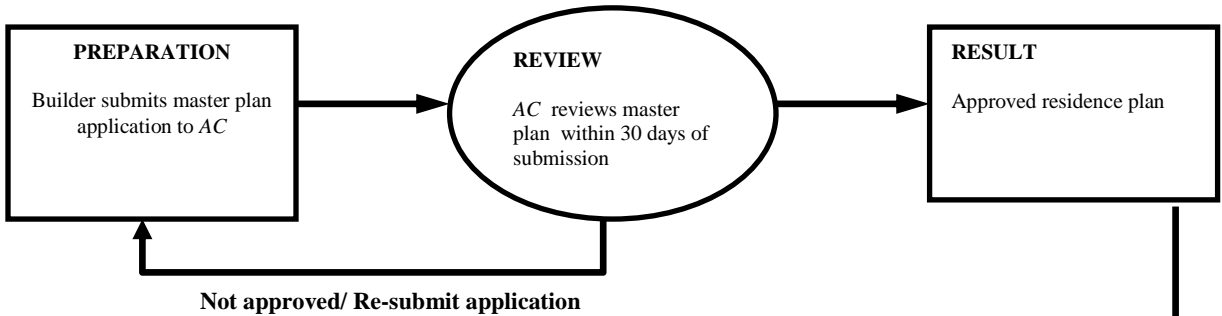

B. Builder Plot Plan/Site Plan Approval Process (Individual or Multiple Units)

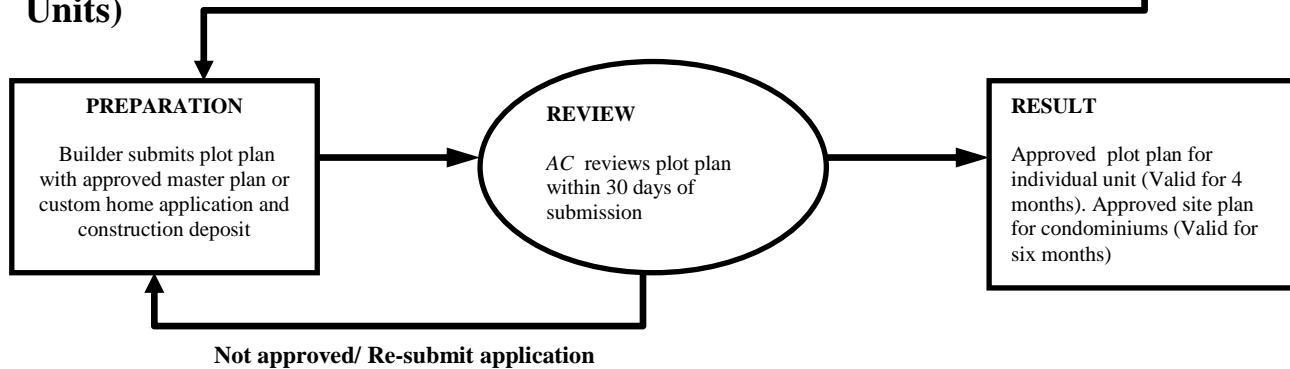

C. Architectural Modification Approval Process (Individual or Multiple Units)

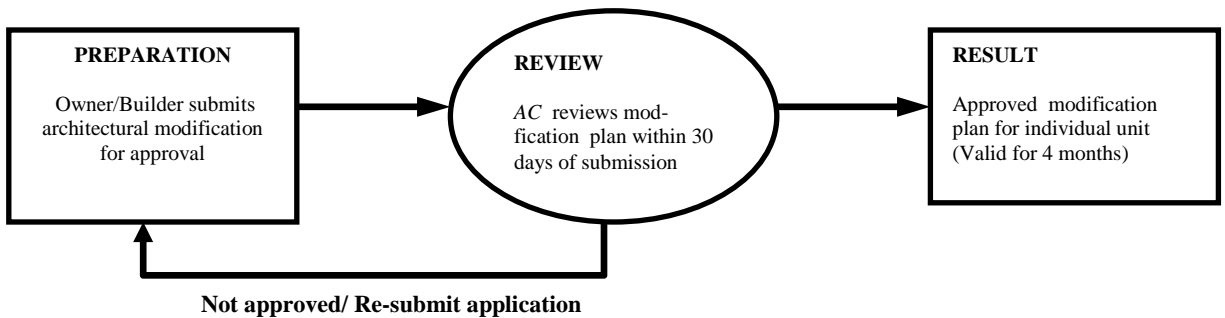

3.3 Owner/Builder Responsibilities

General:

Before any site preparation work can be begin, an *owner* and/or *builder* shall notify the AC at 512-266-7553 of their proper business identification, mailing address and phone number, and a location where such *owner* and/or *builder* may be reached. All *owners/builders* shall be held responsible for the following:

- 1) Compliance with all applicable federal, state, and local building codes and regulations.
- 2) Compliance with all rules, regulations, restrictions and covenants as set out in the Declaration, By-laws of the *Association*, and any applicable Supplemental Declarations or Design Guidelines.
- 3) Compliance with requirements of the Steiner Ranch Residential Design Guideline Manual (as amended from time to time).
- 4) Compliance with plans and submittals approved by the AC. Any deviations from an approved plan must

receive specific approval from the AC.

- 5) Providing qualified personnel to perform all construction activity.

Insurance Requirements:

Coverage

Builders, Contractors, and their subcontractors performing work within Steiner Ranch are required to carry Comprehensive General Liability, Comprehensive Automobile Liability and Workers Compensation Insurance at the minimum coverage levels established by the Texas State Board of Insurance.

Certificate of Insurance

Before commencing any work at Steiner Ranch, *builders* are required to submit a current and valid certificate of insurance to the office of the *Association*. This certificate shall name the *Association* as an additional insured.

Certificates of insurance must be resubmitted on an annual basis or when new coverage is obtained.

Builder's Regulations:

The following criteria pertain to Steiner Ranch homebuilders, the employees, representatives, subcontractors, suppliers,

and service personnel performing work within the community.

- 1) All *builders*, suppliers, and subcontractors, delivery and service personnel performing work in Steiner Ranch are allowed within the property between the hours of 7:00 a.m. and 7:00 p.m. on weekdays and 8:00 a.m. to 6:00 p.m. on Saturdays.
- 2) Construction is not allowed on Sundays and certain holidays as determined by the *Association*.
- 3) The speed limit within the Steiner Ranch is 20 mph, or as posted.
- 4) It is the responsibility of the *owner/builder* and their subcontractors to ensure that crews do not litter Steiner Ranch roads, *units* or surrounding open space areas within the development. If the *Association* notifies a *builder* that a construction site is littered, the *builder* has 24 hours to clean the site. If the condition is found to be unsanitary, the *owner/builder* will have two (2) hours from time of written or faxed communication to clean



3.3 Owner/Builder Responsibilities

- the area. If the *owner/builder* does not comply, a fine will be assessed (see fine/fee list). This will apply to the property under construction, as well as any adjacent properties or *common areas*.
- 5) Portable chemical toilets must be in place on site prior to commencement of construction and removed when construction is completed. One (1) maintained portable chemical toilet will be required for every three (3) houses under construction. The portable chemical toilet must be placed as far from adjacent properties and streets as possible. If it is found that construction has begun without the required number of portable chemical toilets being installed on site, a fine will be assessed. (See fine/fee list)
- 6) A construction office trailer or enclosed storage building is permitted during the time of construction of a particular phase but no more than one month after the last house is built. .
- Sales trailers are allowed during the construction of a model but no more than two (2) weeks after the model is open. All other types of trailers will be evaluated on a case by case basis.
- All trailers must have written **approval** by the AC prior to installation.
- Trailer submittal requirements include, but are not limited to:
- Location
 - Landscape plans (irrig.)
 - Skirting & deck
 - Proposed color scheme
 - Driveway & walkway locations
 - Additional Parking
 - Storage
 - Signage
- Permanent and/or temporary fence installation will be required upon approval of plans for an adjacent residence.
- See Appendix for submittal form.
- All equipment, materials, supplies, and temporary structures must be removed immediately upon completion of the phase that the trailer was approved in. The site must be left neat and clean, as well as re-vegetated.
- 7) All debris, including construction waste, tree limbs, etc., is to be removed both from the lot and Steiner Ranch entirely. Miscellaneous daily debris and trash (e.g., paper, cans, bottles, and litter) must be removed from the job site and properly disposed of on a daily basis.
- 8) A fifteen- (15) yard minimum steel roll-off dumpster for every three (3) lots must be maintained on the site during the duration of construction from commencement of framing operations through project completion. The dumpster must be placed as far from adjacent properties and streets as possible. A regular dumping service must be maintained so that overflow and unpleasant odors do not occur. If it is found that construction has begun without the required number of dumpsters being installed on site, a fine will be assessed. (See fine/fee list)
- 9) Storage bins, if used for on-site material storage,

3.3 Owner/Builder Responsibilities

- must be steel and in good repair.
- 10) Fires of any kind are not permitted.
- 11) Dumping is not allowed within Steiner Ranch. Violators will be prosecuted. *Owners* and *builders* will be responsible for cleanup costs related to the improper disposal of trash, debris and any hazardous wastes, as well as any applicable fines. (See fine/fee list)
- 12) Theft from private *residences, residences* under construction, or of any Steiner Ranch *improvements* will result in immediate prosecution.
- 13) Concrete truck washout or spoils must occur on the *unit* under construction or another *unit* under construction by the same *builder*. The *owner/builder* is responsible for site cleanup and restoration to its original condition for any concrete spoils left on any vacant *unit, common area, greenbelt* or roadways. Applicable fines will be assessed for non-compliance. (See fine/fee list)
- 14) *Builders* or their subcontractors are not permitted to enter the development with children under 16 years of age.
- 15) The *owner/builder* must conduct a weekly site cleanup on each of its lots by the end of the day each Friday. Streets must be kept free of silt, mud, and debris at all times. The *owner/builder* will be required to install and maintain inlet protectors on all inlets that will be affected by run-off from any construction, regardless of its proximity to the actual lot under construction. Periodic street washing will be conducted by the Community Association as necessary, but minimally on a weekly basis. The builder(s) for the applicable areas will be billed by the Community Association for this amount. *Builder* will have twenty-four (24) hours from notification that clean up or installation of inlet covers is necessary. Applicable fines will be assessed for non-compliance. (See fine/fee list)
- 16) Dust control measures must be in place, as necessary, to minimize dust from blowing or being tracked outside of the unit boundaries.
- 17) Optional temporary construction fencing may be installed for security at the discretion of the *owner/builder* with prior written approval from the AC.
- 18) Site and tree protection fencing must be installed along all property lines adjacent to greenbelts, *common areas*, or open space property prior to commencement of clearing or construction. If it is found that construction has begun without the required protection in place, applicable fines will be assessed. (See fine/fee list)
- 19) Erosion control (silt fencing) and protection devices must be installed on all “downhill” sides of property lines of the *unit*, immediately inside the property line, prior to clearing and commencement of construction. These protections must be maintained throughout construction and must remain in place until the area is re-vegetated. If it is found that construction has begun before the

3.3 Owner/Builder Responsibilities

- appropriate erosion controls have been installed, applicable fines will be assessed. (See fine/fee list)
- 20) The volume of recorded music (radios, tape players, etc) must be limited to a level which does not disturb others beyond the construction site.
- 21) If any landscaping item, including, but not limited to, trees, irrigation, or signage, is damaged within Steiner Ranch property, and it can be reasonably assumed the damage was caused by the *owner/builder* (including any contractors or sub-contractors acting on behalf of the *builder*), the *owner/builder* will be notified of the damage and will have (72) seventy-two hours to repair or replace this item by a developer approved contractor. If the *owner/builder* does not comply, the developer will make repairs or replace the item. Applicable fines and cost of repairs will be assessed for any damage at that time. (See fine/fee list)

Conduct and Safety Precautions:

Trespass

No *owner/builder*, general contractor, or any other persons such as employees, subcontractors, suppliers, architects, job superintendents, delivery truck drivers, or other authorized construction workers, authorized by the *owner/builder* or his contractor, shall enter upon the property of any other *owner* for any reason at any time without the permission in writing of the *owner/builder* of such property.

The use of any adjacent property for any purposes, including vehicular access, parking, or equipment and material storage, will not be permitted without the written permission of such adjacent property *owner*.

Compliance with Directives

Authorized persons must follow the directives of the *Declarant*, Developer, the security staff, the *AC*, representatives of the management company that has been retained by the Board for the management of the project, and any other persons designated by the Board.

Prohibited Activity

- 1) Alcoholic beverages are not to be consumed on the property.
- 2) Dogs and other animals are not permitted on any construction site.
- 3) Nothing is to be done on the construction site that will damage or disturb the work or the activity on any adjacent *unit* or Common Area.
- 4) Access to the "greenbelt" areas without the written permission of the *Association* through the *AC* and without placing a refundable deposit is strictly prohibited.

Safety Precautions

The *owner/builder* must take all necessary precautions for the safety of all persons, materials and equipment on or adjacent to the *unit*. An approved barrier, lights, signs, and other safeguards must be erected, furnished, and maintained. Adequate warning must be given to everyone on or near the *unit* of dangerous conditions during the work.

Site Maintenance

The *owner/builder* will be responsible for ensuring that the site is maintained daily in a neat and clean condition. All materials delivered to or generated by the work must be neatly stockpiled.

3.4 Construction Inspections

Introduction:

In order to ensure that construction *improvements* are completed as approved, the *AC* or a designated representative will conduct a construction inspection. The inspection process is intended to cause little or no delay in the construction schedule.

Inspections

The *AC* and any persons or committees designated by the *AC* shall have the right to conduct periodic inspections to verify that the *owner/builder* is complying with all of the provisions of the Regulations and Declaration and to ensure that the construction of the *improvements* is proceeding in accordance with the approved plans and specifications and in accordance with water conserving measures.

It is the responsibility of the *owner/builder* to notify the *AC* of when the *improvement* is ready for each inspection.

Enforcement

The *Association* will have all of the available remedies permitted by the Declaration and By-laws to enforce the Regulations, which include the Design Guidelines. Such rights include, but are not limited to, stopping the construction if any *owner/builder*, general

contractor, job superintendent, subcontractor, supplier or any of their employees is in violation of any provision of these Regulations, and removing or causing the removal of any *improvements* that have been made or constructed in violation of any of the provisions of the regulations or the approved plans and specifications, as well as a substantial fine for non-compliance. (See fine/fee list)

A diagram is included at the end of this section illustrating the overview inspection process (page 24).

Builder New Residence Construction:

The architectural approvals coordinator for each *builder* must provide a copy of the approved "Submittal Cover Sheet," plot plan, and other approval requirements to their field superintendent for proper construction implementation (See Submittal Requirements, Section 3.1 for more information).

On-site cut or fill and setting foundation forms may not begin until the *owner/builder* has received the architectural plot plan application approved by the *AC*.

Any special notes or conditions of approval should be brought to the attention of the *owner/builder* at this time. If the *owner/builder* has questions about the *AC*'s approval, he should contact a representative for clarification.

Scheduling

The *owner/builder* must schedule a plot plan review **prior** to commencement of any construction on the site. The purpose of this inspection is to review the proposed house layout, lot grading, and to insure that silt fencing and tree fencing are in place prior to foundation commencement.

Form Survey: The

owner/builder must submit a form survey **prior** to pouring concrete. The purpose of this survey is to verify that site grading, foundation location, and brick ledge step-downs, if any, have been prepared according to the approved submittal and the regulations.

If the *owner/builder* pours a foundation without receiving a written form survey approval, the *owner/builder* may be responsible for removing and replacing the foundation in accordance with the approved submittal.

3.4 Construction Inspections

Final Survey: Before a final inspection may be completed a copy of the final survey must be submitted to the AC Coordinator for review.

Final Inspection: Upon completion of all *improvements*, and **within (7) seven days of the homebuyer's closing or occupancy**, the *owner/builder* must notify in writing the AC coordinator the construction is complete and the *improvement* is ready for a final inspection.

If the residence is closed without an inspection, a fine will be assessed (see fine/fee list). If the property fails to pass the initial inspection, there will be a re-inspection fee for each additional inspection (see fine/fee list).

Decks, patios, sidewalks, fencing, and landscaping must be complete at the time of the final inspection.

The homeowner's association will hire an inspector to perform the final construction inspection, per the architectural guidelines. The AC Coordinator will inform the inspector of any new or re-inspections by every Friday at noon. The inspector will complete a Construction Inspection Report at Final Inspection. The home-building superintendent, main office

and home-owner's association will be notified of the results by the following Monday.

If the *improvements* appear to be in compliance with the approval, the inspection report will note this compliance; otherwise, deficiencies will be noted and provided in writing to the *owner/builder* as noted on the inspection process chart (see page 24). These deficiencies must be corrected prior to Final Inspection approval. A follow-up inspection will be automatically scheduled for two weeks from the date of notification, unless otherwise notified by the *owner/builder* that the deficiencies will not be corrected by that time. A one-time hold will be allowed for each residence for up to thirty (30) days. At that time, the house will be automatically scheduled for re-inspection.

Architectural Modifications:

Construction may not begin until owner/builder has received a letter from the AC approving the proposed construction. Once construction is completed, the *owner/builder* must send a written request to the *Association* or its designated representative, to schedule an inspection of the

improvements. If the inspection is not scheduled or an extension not requested within (7) seven days of the scheduled completion date, a fine will be assessed.

After its final inspection, the *Association* shall complete a "Construction Inspection Report," (see attached sample form in the Appendix) one copy will be mailed to the *owner/builder*, the original will be placed in the *Association* property file.

If the *improvements* appear to be in compliance with the approved plans, the inspection report will note this compliance. If the inspection indicates that additional work is necessary (or is in non-compliance), the *owner/builder* will be required to complete the *improvements* as noted in the inspection report and schedule another inspection. Fines will be assessed for each re-inspection necessary until the improvement is compliant.

3.4 Construction Inspections

INSPECTION PROCESS OVERVIEW

The diagrams shown below are schematic only. Refer to text in this section for detail description

A. New Unit Inspection Approval Process

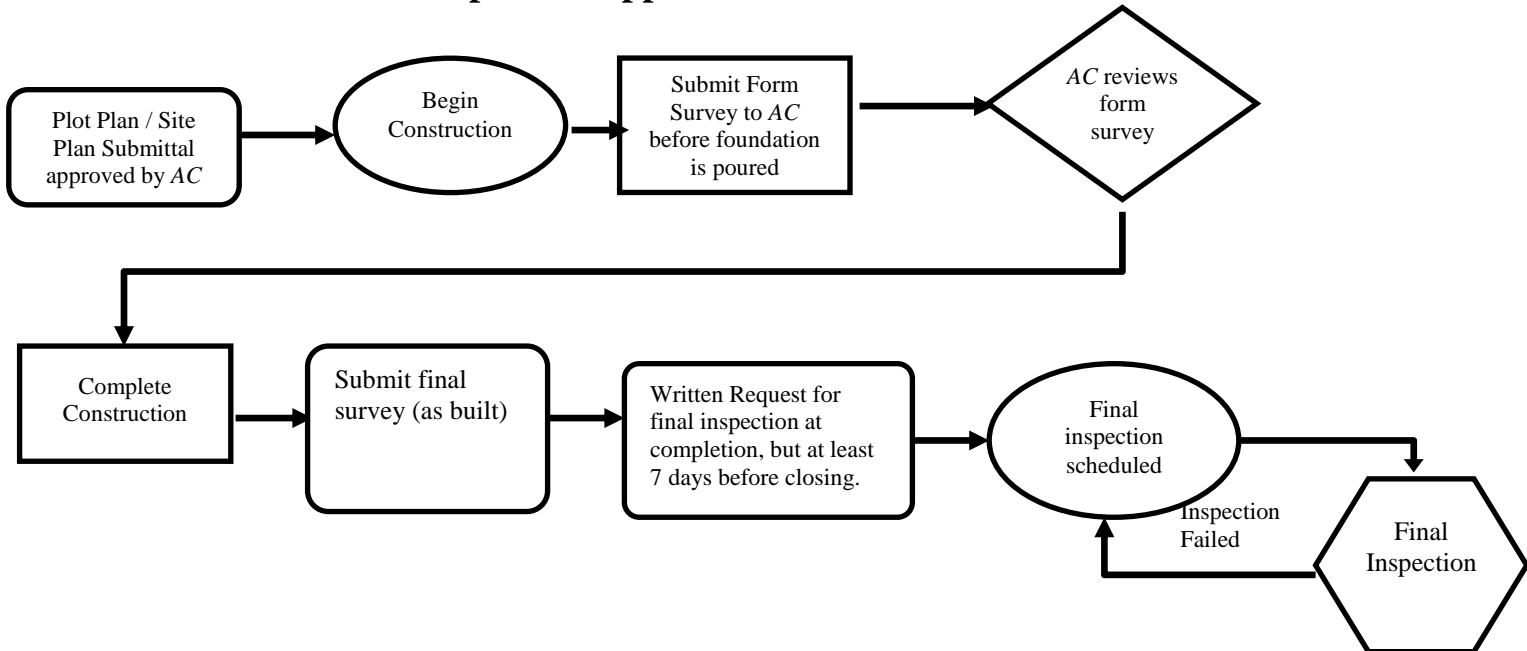

B. Architectural Modification Inspection Approval Process

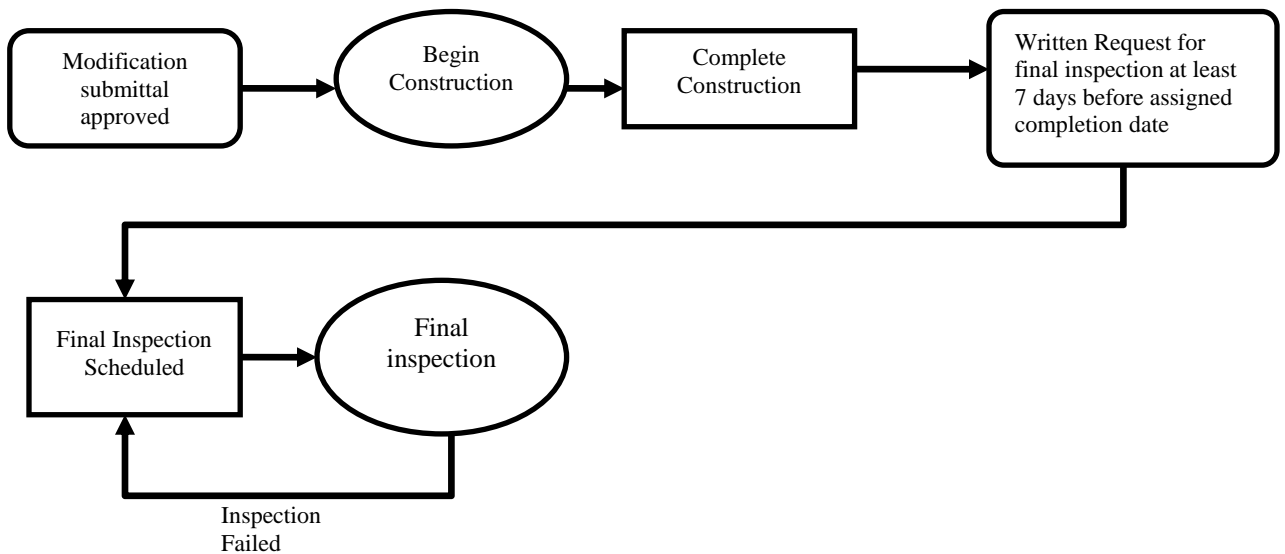

4. Site Construction

Introduction:

Some careful planning before construction activities begin can greatly enhance the site's appearance and help lower construction costs.

Preserving existing vegetation will give Steiner Ranch an appealing and tree-shaded appearance. Numerous stands of Live Oak, Cedar Elm, Juniper, and other tree species should be considered a valuable asset.

In addition, the native landscape elements are drought tolerant, thus reducing the need for extensive watering of non-native plantings.

Sections:

- 4.1 Construction Site Management
- 4.2 Preserving and Protecting the Environment

4.1 Construction Site Management

Goals:

Minimize the negative visual impact of construction through the thoughtful handling of construction activities and the maintenance of an orderly job site.

Requirements:

Participate in the Keep Austin Beautiful Clean Builder Program. Call 499-3576 for more information.

Construction vehicles and all workers' personal vehicles are limited to paved roads and approved access roads. Parking is also permitted on the *unit* being developed. No parking or access is allowed on *common areas*, "greenbelt" areas, sidewalks, or adjacent undeveloped *units*, unless

prior approval is obtained and a deposit is placed with the *Association* to insure the area is left undamaged. The request for access to any *common areas* must be made in writing to the *AC*. Construction may not begin unless and until written approval is received from the *AC*. When construction is complete, the deposit will be refunded less any costs incurred for damage to the *common areas*.

Each *unit* may be served with underground electricity, cable TV, telephone, sewer, gas, and water lines. The location of these utilities must be confirmed by the *owner/builder* in the field prior to

construction. Building debris must be cleaned up and removed weekly. No construction debris, brush, rock or fill may be placed on any *unit* other than the specific *unit* under construction.

The same *builder* may wash out concrete trucks only on the *unit* under construction.

Units must be re-vegetated within ten (10) days after the *residence* is substantially complete. See Landscape Guidelines, Section 8, for specific requirements.

Construction must take place in accordance with the City of Austin Erosion and Sedimentation Control Manual as well as the Regulations herein.

Prior to clearing the *unit*, silt fencing must be installed on the downhill side(s) of the *unit*, and at the street curb, as necessary.

Prior to clearing the *unit*, the permanent fencing must be installed along all property lines abutting a greenbelt, golf course, or open space area. In the case of sections which require or allow wrought iron style fencing, additional five foot (5') high orange tree protection fence must be installed and continually maintained with the wrought iron style fence

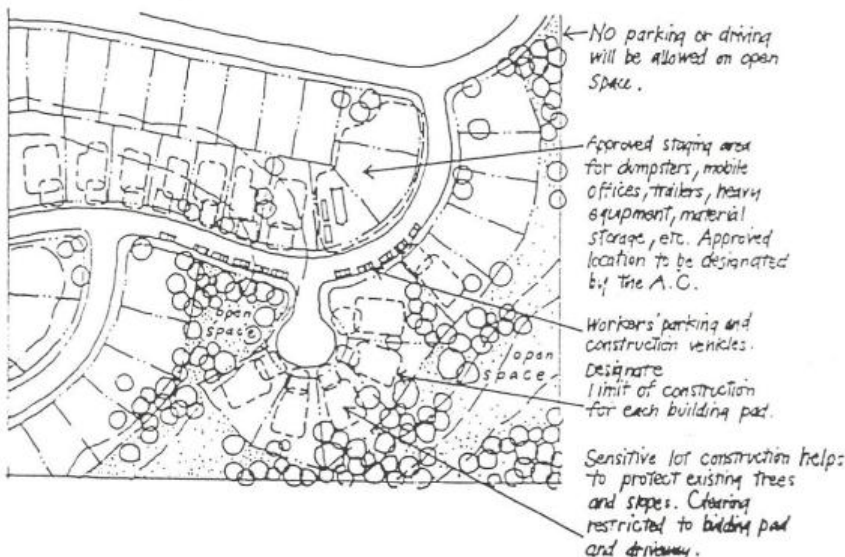

4.1 Construction Site Management

to prevent debris from blowing through to adjacent properties. If the subdivision does not require fencing, then the five foot (5') high orange tree protection fencing must be installed and continually maintained along all property lines abutting greenbelt or open space area.

Builder construction access, parking, construction staging, materials or debris storage, or any construction activity is prohibited on greenbelt areas, open space areas, or any vacant residential *units*, unless prior approval is obtained and a deposit is placed with the *Association* to insure the area is left undamaged. The request for access to any *common areas* must be made in writing to the *AC*. Construction may not begin unless and until written approval is received from the *AC*. When construction is complete, the deposit will be refunded less any costs incurred for damage to the *common areas*.

Clearing cannot begin on any *unit* until temporary erosion controls are in place (silt fences, etc.) and required permanent fence or five foot (5') high orange tree protection fence as required when abutting a greenbelt or open space area, protecting all adjacent properties, *units*, and streets. If *unit* clearing

involves the removal of any existing temporary erosion control, the *builder* must tie the new erosion controls back into existing erosion controls. Erosion controls must remain in place until the yards are landscaped and vegetation established and then must be removed by the *owner/builder*. The *owner/builder* must keep the streets silt-free at all times, "washing down" streets as frequently as necessary. Please see *owner/builder* responsibilities for more information.

The *owner/builder* is required to install and maintain filter fabric at all storm drain inlets downhill from a *unit* under construction. The *owner/builder* must clean and maintain filter devices continuously through the construction phase. Please see *owner/builder* responsibilities for more information.

Clearing and rough grading may begin only when construction is imminent, no more than ten (10) days in advance of setting forms.

Disposal of Spoils

Any spoils generated from the site grading of a *unit* must be relocated on such *unit* or promptly removed to an approved, permitted spoils dump site in accordance with City of

Austin and Travis County rules and regulations.

No material may be placed or stored on the street, *Association* property, adjacent *units*, or any other portion of the property covered by the Declaration or owned by the Developer.

The *owner/builder* who is responsible for the construction shall be liable for any cleanup costs, accidents, or removal of such spoils if deposited anywhere other than his *unit*.

Utility Adjustments to Fine Grade

All manholes, utility structures, or other devices, including meters and meter boxes, within the *unit* boundary must be raised or lowered at the completion of construction to coincide with the elevation of adjacent finished grade of the *unit*.

Guidelines:

Locate temporary utilities, equipment storage and job trailers in areas that are not visible from major roadways, and as approved by The *AC*. These items cannot be located under the dripline of the trees.

To lessen soil compaction and tree root damage, driving and parking of construction vehicles on the *unit* should be minimized.

4.2 Preserving & Protecting the Environment

Goals:

Preserving existing vegetation and maintaining a native Hill Country community character.

Requirements:

Construct approved, temporary fencing around trees to be preserved, in accordance with the City of Austin Environmental Manual. *Unit* clearing should be the minimum necessary to construct the driveway and residential residence footprint.

No clearing is permitted within 10 ft. of any conservation easement. These may be designated at the rear of *units*, which back up to ravines (check final plat for exact locations).

Note: Refer to the Approved Plant List, Section 8.4, for supplemental planting suggestions in these areas. Plants indicated as “drought tolerant” are appropriate for most areas of Steiner Ranch.

Tree surveying and tree protection measures must comply with applicable City of Austin ordinances.

All plot plan submittals must include a survey of all trees eight (8) inches and larger in diameter, within the limits of construction. Trunk diameter, crown diameter, and tree type must be shown. Protected trees defined as having a 19-1/2 inch diameter (60” circumference), which are removed or destroyed must be replaced with an equal or greater caliber.

The AC may require the proposed location of a residence to be relocated on a lot to save significant trees. Significant trees are defined as any tree that is eight inches (8”) or greater in diameter.

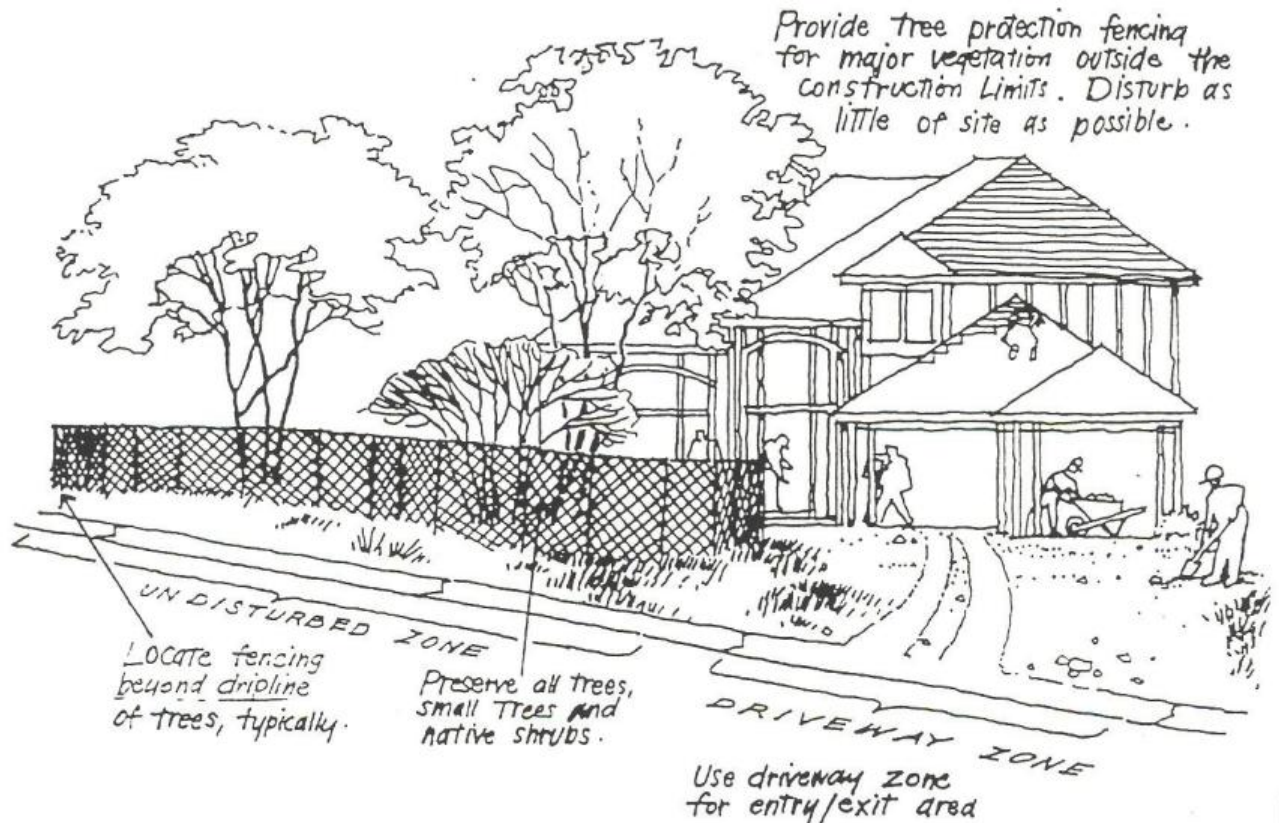

4.2 Preserving & Protecting the Environment

Guidelines:

All native trees and shrubs outside of the *residence* footprint should be preserved. Limit cut and fills around existing trees to 6” within the dripline.

Any grade change in excess of 6” within the dripline zone should be handled by the use of retaining walls or a tree well constructed at the tree’s dripline. See Retaining Wall Guidelines, Section 7.3.

It is recommended that **builders** participate in the City of Austin, “Green Builder Program” by constructing energy efficient and environmentally sensitive homes. Contact the City of Austin Environmental and Conservation Services Department at 499-3500 for more information.

5. Building/Site Relationship

Introduction:

Careful siting of the *residence* footprint and driveway on the *lot* can maximize the site's character.

Existing vegetation can be preserved, potential views can be enhanced, privacy can be created, and outdoor spaces can be optimized.

Sections:

- 5.1 Building Setbacks
- 5.2 Impervious Cover
- 5.3 Building Orientation
- 5.4 Grading and Drainage

5.1 Building Setbacks

Goals:

A pleasing variety of residential streetscapes.

One means of creating a pleasing streetscape is through variations in the front yard building setback. Setback variations set up a rhythm in the spatial quality of the streetscape zone. This promotes a dynamic architectural composition.

Building Area

“Buildable Area” is defined to mean the portion of the *unit* other than the setback areas of such *unit*, as described herein. The *residence* must be constructed completely within the Buildable Area.

Requirements:

The AC will review all submittals to ensure that each *residence* is located in an optimum manner, which preserves existing vegetation and significant trees (any tree greater than eight inches (8”) in diameter). Existing vegetation enhances the streetscape and retains the natural character of Steiner Ranch.

Refer to Final Subdivision Plat and/or specific neighborhood Design Guidelines and Supplemental Conditions.

:

Setbacks will be measured from the outline of the footprint of the residence, including any covered or uncovered

portions of the foundation to be used as porches or patios, etc. to the property line or edge of pavement on joint-use driveways. While eaves and overhangs are not used in determining setbacks, this portion of the structure will not be allowed to project into an easement.

No roofed or trellised structure separate from the main *residence* structure may be built within a setback area (i.e., gazebo, pool cabana).

Pools and spas must be constructed at least five (5) feet from any *unit* property line, “open space,” or Common Area. Lots adjacent to golf course lots must be set back at least ten feet (10’).

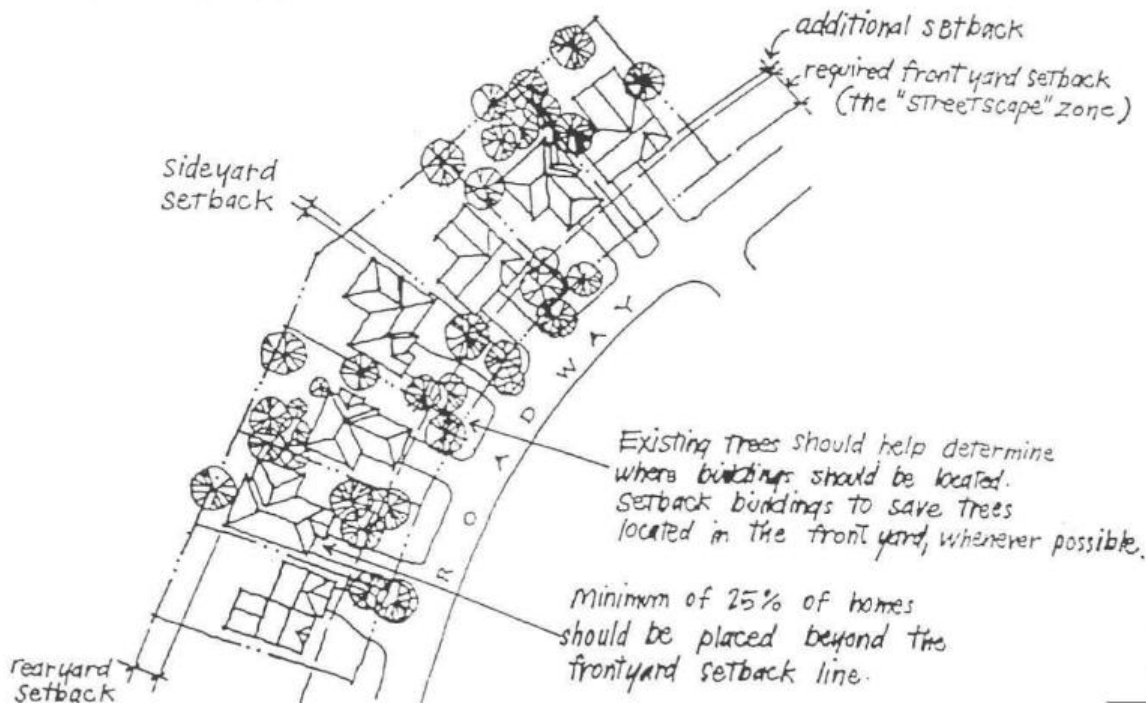

5.1 Building Setbacks

Sport Courts and will be reviewed on a case by case basis when submitted for Architectural Modification Approval.

Side street entry garages must be set back a minimum of twenty (20) feet from the side street property line if there is a street sidewalk required on the subdivision plat.

AC must approve all structures and accessory features of any type through the Architectural Modification Process as stated previously.

Apart from these Regulations, governing agencies for pools and spas requires special fencing enclosures.

Owner shall be prohibited from making any *improvements*, including pool, spa and fencing, within or upon, or which encroach into or cantilever over any *Common Area* or open spaces.

Please see section 10. Condominium Guidelines for setback requirements in a condominium community.

Condominium Guidelines:

At least 25% of a *builder's residences* on each street should be setback at least 4 ft. beyond the required setback in order to vary the streetscape. A maximum of two (2) homes in a row should be built on the front yard setback line, and a maximum of 15' difference in setbacks is allowed.

A variance may be granted for unusual topographical situations, at the sole discretion of the AC.

Side yard setbacks between *residences* should be varied. This also assists in creating spatial variety in the streetscape.

Setback variations allow for *residences* to be adjusted around existing trees (see diagram on next page).

Homes should be arranged to provide outdoor living spaces for people.

Key factors in determining variations in the front yard and side yard setback beyond the minimum requirements include:

- 1) Appropriateness to unique site conditions, including steep slopes or location of site features

such as rock outcroppings.

- 2) Location of existing trees.
- 3) Setback compatibility of adjacent homes on either side and across the street from the lot.
- 4) Potential views towards a greenbelt or sight lines beyond.
- 5) Detached garages and side entry garages are encouraged in Steiner Ranch.

Final approval of setbacks is determined by the AC when the plot plan or site plan is submitted for approval.

5.2 Impervious Cover

Goals: Minimizing impervious cover.

Minimizing impervious cover serves two purposes: it encourages water to percolate into the substrata; and it minimizes erosion and limits sediment and pollution deposition into the canyons, creeks and Lake Austin by reducing the volume and rate of water runoff. These actions help conserve Steiner Ranch's important natural amenities.

Requirements:
Limiting impervious cover is required for compliance with specific subdivision

development restrictions and the City of Austin Land Development Code and/or the restrictions of current governing jurisdiction.

Maximum impervious cover allowance per *unit* is restricted by subdivision plat note. Impervious cover includes driveways, parking areas, buildings, patios, walks and other impermeable construction elements.

Pedestrian sidewalks within public right-of-ways are excluded from the impervious cover allowance.

Note:
Plot Plan submittals are not reviewed for compliance with governmental jurisdiction impervious cover plat requirements. It is the responsibility of the owner/builder to comply with all such requirements or regulations. By approving such plans, neither the *Declarant*, the *Association*, the *Developer*, or its ownership entities, the *Board*, nor any committee worker, nor agents, employees, attorneys or consultants of any of the foregoing shall be liable for any damages or losses arising out of or as a result of said approvals.

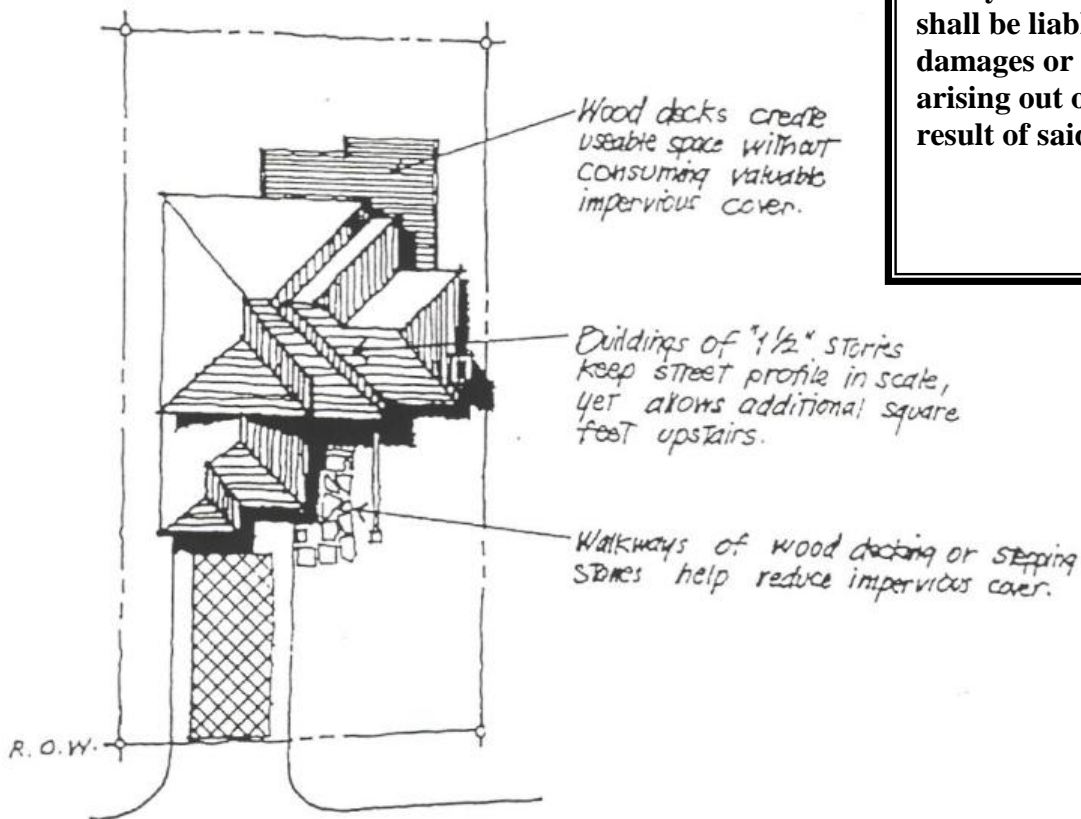

5.3 Building Orientation

Goals:

Integrating the *residence* onto the *unit* while maintaining compatible relationships with adjacent *residences* and the street frontage.

Guidelines:

The *residence's* primary living areas, both interior and exterior, should be arranged to take advantage of the building-to-site relationship.

Attention should be given to the quality and usability of the outdoor spaces formed by the exterior walls of a *residence* and adjacent fences.

Care should be taken to avoid placing the private areas of one *residence* adjacent to the public areas of another *residence*.

Although view preservation is not guaranteed, consideration should also be given to the views from adjacent *residences*.

Placing such elements as balconies, enclosed courtyards, patios, decks, and entrances where appropriate should encourage the use of the front, back, and side yards. Do not think of the backyard as the only area suitable for outdoor living.

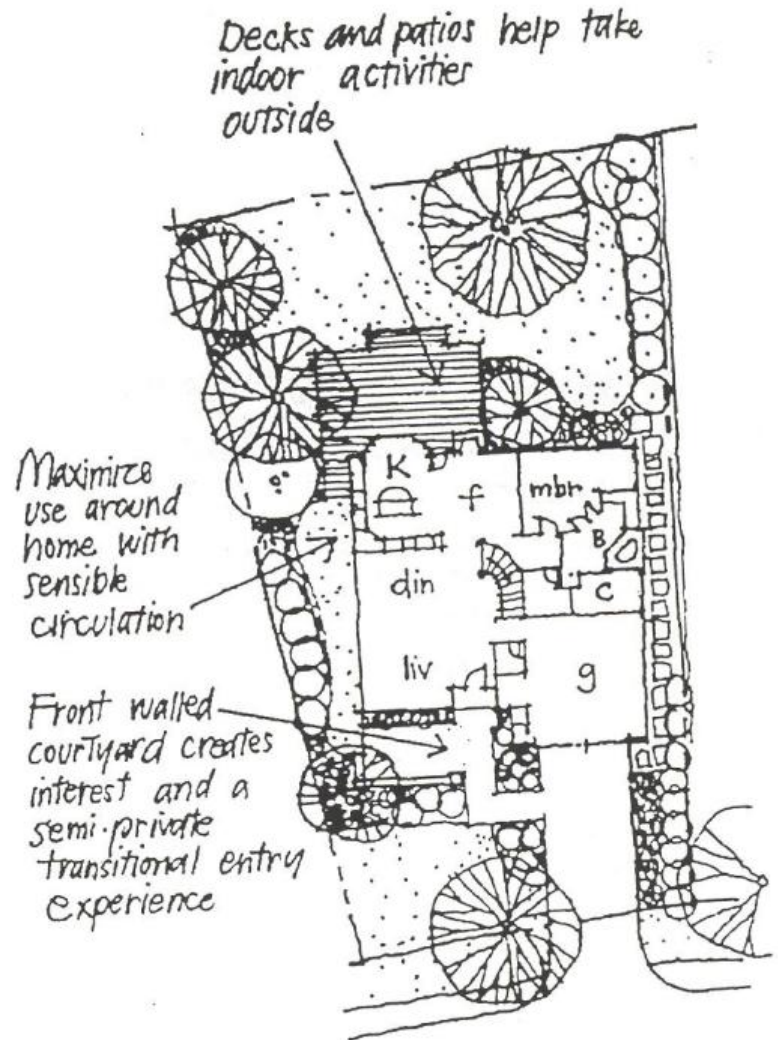

5.3 Building Orientation

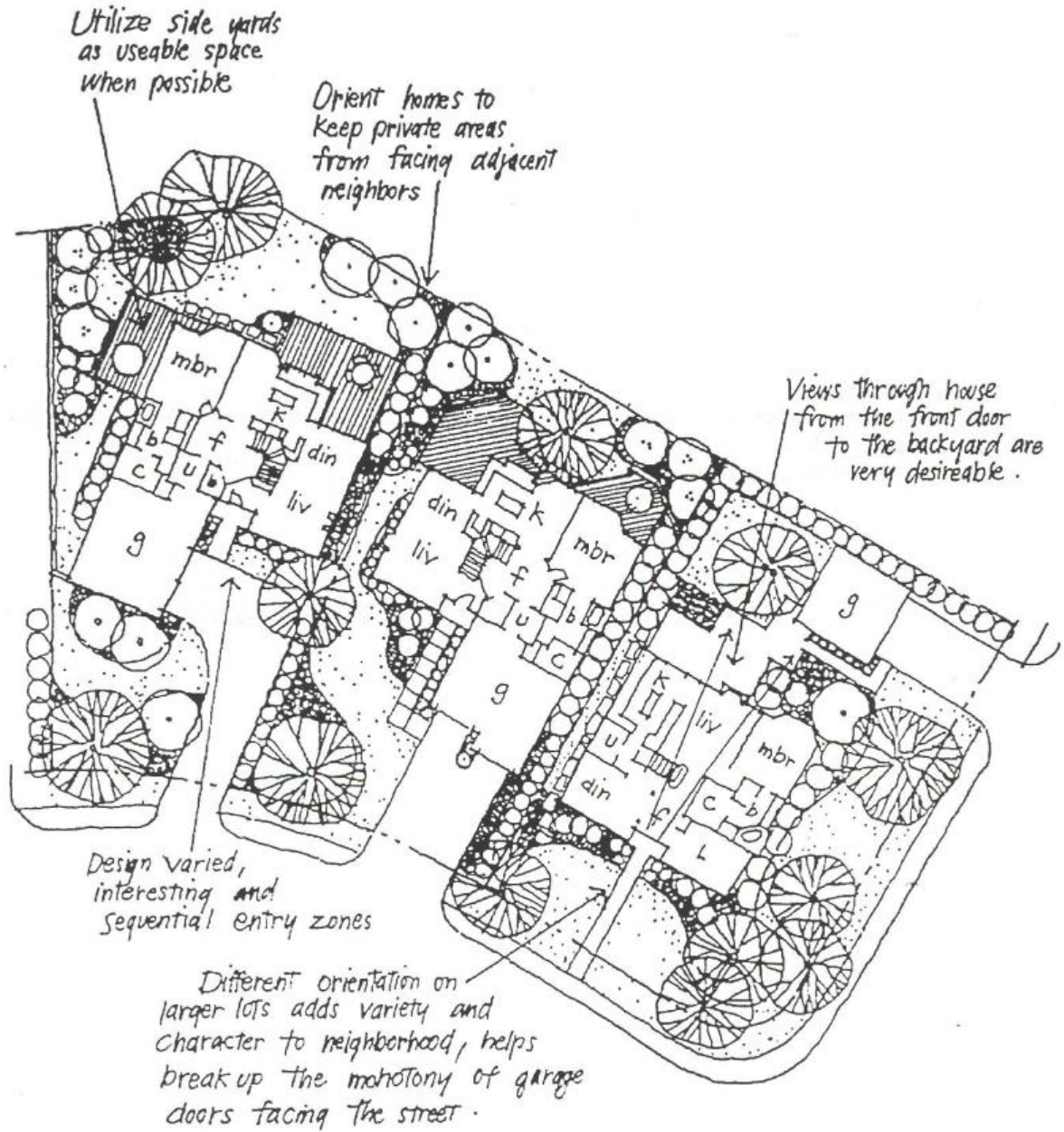

5.4 Grading & Drainage

Goals:

Site grading which compliments and reinforces the overall architectural and landscape character.

Requirements:

Grading must be done in conformance with the final plat notes. Minimizing cut and fill helps to preserve existing vegetation and the natural landform. The owner/builder must also consider the flow of water from adjacent properties and how it relates to their own drainage, and make accommodations.

Internal, on-site drainage is the responsibility of the owner/builder.

Slope grades may not exceed 3:1 without slope protection per City of Austin standards. All cut slopes exceeding a 3:1 slope must be covered with approved slope protection per City of Austin standards.

Retaining walls must be constructed using coursed "dry stack" limestone in an approved design. Dry stack limestone retaining walls are required when a retaining wall is necessary at any cut or fill condition (see Retaining Walls, Section 7.3).

Guidelines:

The overall grading and drainage system for Steiner Ranch has been designed to promote overland flow of run-off where possible. Site drainage handled by overland flow rather than within enclosed sewers is encouraged because of the cleansing and recharge properties of filtration and infiltration.

Grading should be done so that changes in elevation are gentle and natural in appearance and retain an informal appearance by smooth variations in the contours.

The example on this page addresses approved guidelines when grading around existing trees to be preserved.

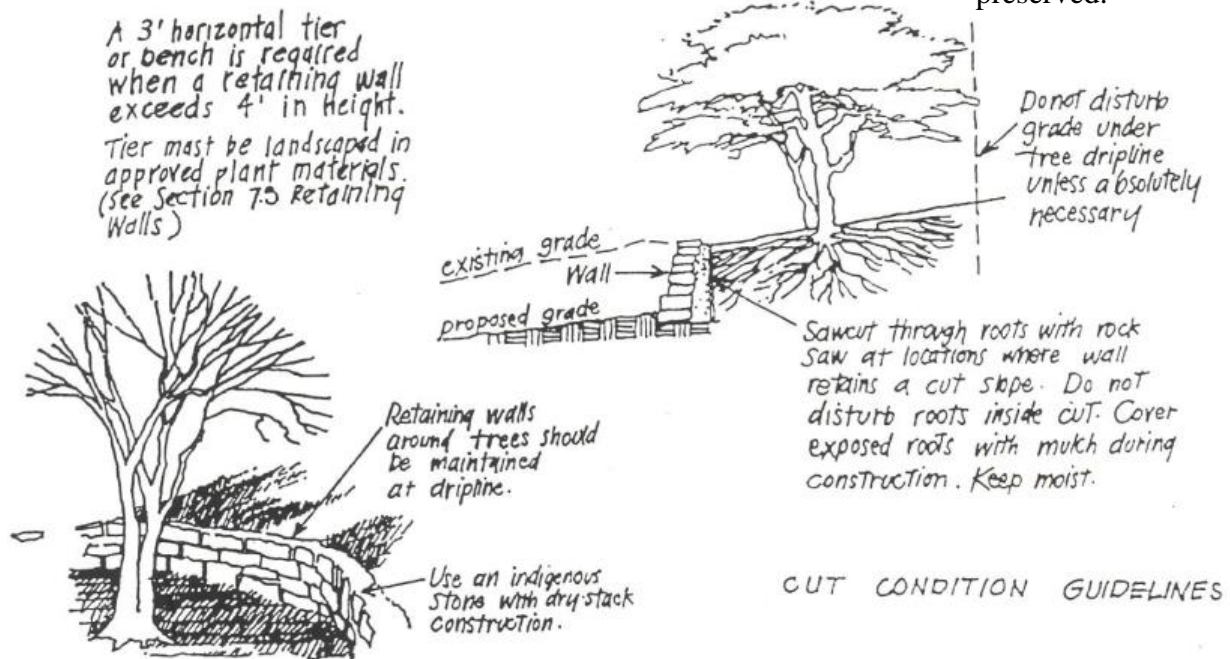

TREE WELL RETAINING WALL

Introduction:

Good building design, along with the natural site characteristics, helps establish a positive identity for a community. An image is initially established through subdivision planning and landscape design.

However, it is the construction of well-designed *residences* that completes the picture. These *regulations* provide a framework for establishing a consistency throughout Steiner Ranch. Attention to detail is critical in achieving this desired image.

Sections:

6.1 Façade Design

6.2 Foundations

6.3 Height Limit

6.4 Roofs

6.5 Chimneys

6.6 Garages

6.7 Energy Saving Features

6.1 Facade Design

Goals:

The goal here is to design homes that relate to their surroundings to create a harmonious blend of the built and natural environment within a Hill Country context.

Requirements:

At least 70% aggregate total of the exterior walls of a home must be *Masonry*, *Stucco*, or approved equal. Refer to Master Plan Submittal Application Form for calculation method. Master plans are approved with the *Masonry* or *Stucco* elevations as submitted. If changes in the *Masonry* or *Stucco* configuration are made, an elevation noting the *Masonry* or *Stucco* changes must be submitted with the plot plan application. This includes any *Masonry* or *Stucco* accents added around doors or windows, as well as a change in *Masonry* or *Stucco* types. This does not apply if the change is made from stone to brick, or vice versa.

Any portion of the exterior, which faces a street (side or rear façade), must be 100% *Masonry* or *Stucco* and a single material type to match the first floor *Masonry* or *Stucco* (i.e. stone on the first floor requires stone on the second floor), unless

submitted to and approved by the AC in writing. This requirement applies to *units* backing up to major streets and collector streets, corner *units*, or *units*, which have permanent open space to either side or on the rear façade when the *residence* is visible from a street. This requirement may be modified in areas of specific architectural treatment or detailing created for particular design interest. These areas must be approved by the AC. **Refer to specific neighborhood Design Guidelines and Supplemental Conditions for specific Masonry or Stucco requirements.**

Masonry and *Stucco* must “wrap” corners at the intersection of the first floor front and side elevations a minimum of 8’ or the depth of the front room located on the upper level. (see Figure 6.1.1) On street facing sides, where wainscot is used on the front elevation, the wainscot must continue along the length of the wall or until it is screened by wood fencing. In addition to all other *Masonry* or *Stucco* requirements, “split-level” plans, where the first floor lies below the street elevation, will be required to extend the *Masonry* or *Stucco* on the street elevations (both sides) to at least 50% of the overall

depth of the residence. (See figure 6.1.1)

Exterior façade materials must be natural and authentic or specifically approved. Painted Brick is not allowed.

Prohibited exterior materials include, but are not limited to: exposed smooth-faced concrete blocks, plywood, log, plastic masonite sheathing, and metal siding (horizontal concrete lap is acceptable). Certain vinyl siding products may be considered but must be approved by the AC.

Colors must be approved. Warm, earth-tone neutrals are required, with muted, complimentary colors suggested as accents.

The same *residence* plan, regardless of elevation, shall not be constructed within two *residences* adjacent on either side or the three *residences* directly opposite from the subject *residence*, to include *residences* across the side street for corner lots. (See diagram page 41). Variances may be considered on an individual basis for dramatically different elevations. A variance request form must be submitted to the committee for review/approval before plot plan submittal.

6.1 Facade Design

Different *Masonry* or *Stucco* color is required for the two residences adjacent on either side and the residences directly opposite from the subject residence. A *Masonry* or *Stucco* color, or one deemed too similar by the AC, cannot be used more than twice in the eight house block. Stone (any color) may occur twice in a four-house block, but may not be located to either side of the subject house. On-site stone samples are required for all custom homes, and may be requested by the committee for production homes. If required or requested, the on-site sample must be either a 6'x9' sample on the house, or a 6'x9' free-standing sample. The above *Masonry* and *Stucco* color restrictions will still apply if no more than two of the same color group in an eight house block. (see diagram –this page).

Bright, flashy materials, such as reflective glass, are not permitted. Different color schemes are required on elevations that are repeated in the subdivision.

Address number must be clearly indicated on the front of the house, and illuminated. The use of pre-cast stone address blocks is encouraged. If the owner/builder wishes to install the address block in a location other than on the front of the house, he must submit a proposal to the AC

for review/approval. Homes which are setback 40' or more from the street or the joint access drive will be required to have an address monument approved by the committee at the street or access drive. Placement of the address monument sign must be such that it is illuminated, or additional lighting is added to illuminate the sign, it must be at least 2'x2'x2', constructed of *Masonry* or *Stucco* similar to the main structure, and have pre-cast stone address blocks, or other as approved by AC.

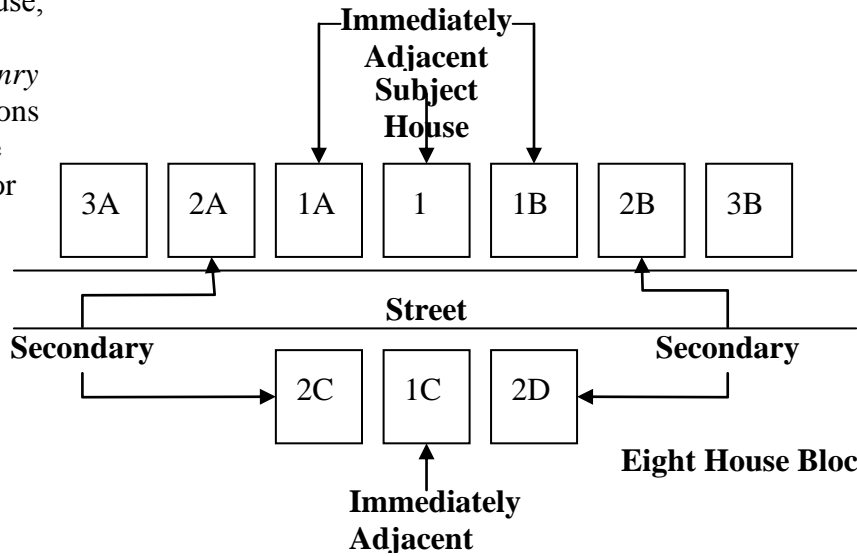

Residences = Different residence plan, elevation and *Masonry* or *Stucco* color from subject residence

1A, 1B, 1C,
2A, 2B, 2C
And 2D

RESIDENCE VARIATION REQUIREMENT

Note: Stone, any color, may occur only twice in a four-house block, but may not be located to either side of the subject house. The *Masonry/Stucco* color restrictions still apply.

6.1 Facade Design

Awnings on street facing elevations are not permitted. The AC must approve all other awnings.

Please see section 10. Condominium Guidelines for façade design requirements in a condominium community.

Guidelines:

Entrances to *residences* should be clearly defined, protected by a covered porch, and integrated with the building design.

The use of recessed windows and the expression of columns and beams that create shadow and texture are encouraged to establish a sense of residential scale.

Break up the elevations to provide shadow relief. Use recessed areas, offsets and “popped out” areas to create interest. Consider offsets where rooflines change

The use of new or innovative building materials for façade design is encouraged and, when compatible with façade requirements, may be approved.

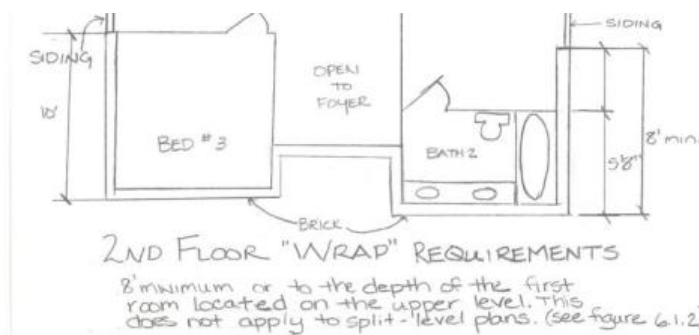

Figure 6.1.1

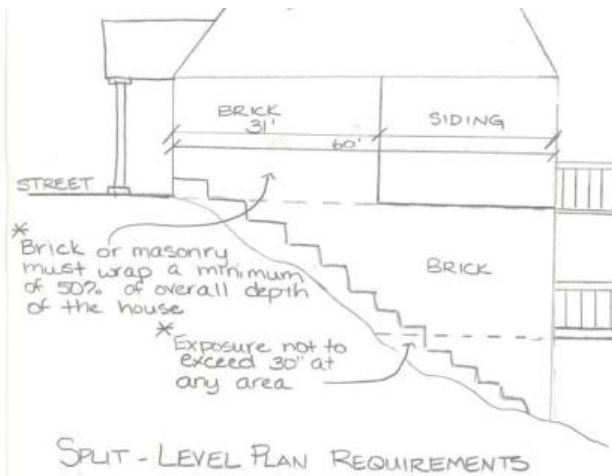

Figure 6.1.2



6.2 Foundations

Goals:

Minimizing the amount of exposed building foundations (underpinning).

In hilly or rolling terrain, it is sometimes necessary to allow for several feet of grade change across the floor-plate. Therefore, careful foundation and elevation design is required in planning the home to comply with the design requirements.

Requirements:

Exposed foundations (including but not limited to stairs, front porches or any other projection on the front elevation) shall be limited to 12" height on front elevations, as well as all other elevations facing streets (whether side or rear elevations).

For interior side elevations, a *Masonry/Stucco* "wrap" must complete the corners to at least a minimum of 8' of the side wall to maintain the exposure of less than 12" above finished grade.

The height of exposed foundations is limited to 30" on all other sides and rear elevations not visible from the street or golf course (see sketch below). "Split-level" plans are also required to have no more than 30" of exposed foundation and should be stair-stepped, as shown in Figure 6.1.2, so no area of the exposed foundation exceeds 30".

Exposed edges of all porches, including front porches, must be concealed by the finish grading process or veneered in *Masonry* or *Stucco*. If the house is complete and the foundation exposure exceeds the limits, the *builder* will be required to screen the exposed foundation with a planter wall with shrubs tall enough to immediately screen the foundation and will be assessed a fine for non-compliance with the above guideline (see fine/fee list).

Refer to specific neighborhood Design Guidelines and Supplemental Conditions for specific screening requirements

Masonry or *Stucco* veneer may be deleted under rear yard decks, which are screened with lattice (See Wood Decks, Section 7.8).

* Re: 7.8 Wood Decks for screening requirements.

** Exposed Foundation: 12" height maximum for front elevation, 8' of the interior side & all elevations facing public streets 30" height

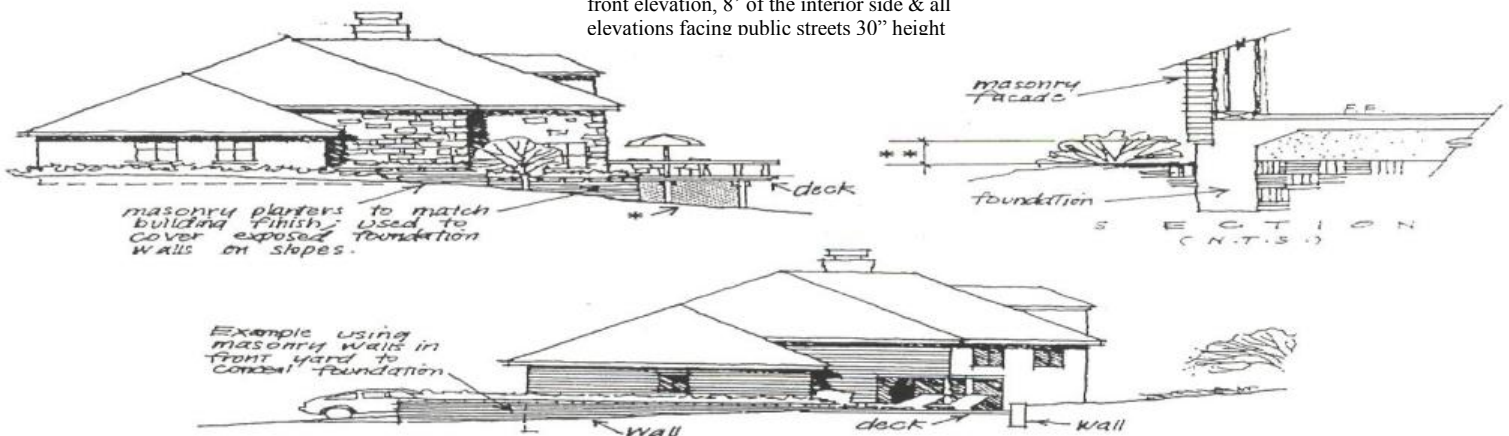

6.2 Foundations

Minimize the amount of exposed foundation by dropping the *Masonry* course. The *Masonry* ledge must extend around building corners a minimum of two (2) feet before stepping up or down to the less restrictive foundation requirement. The step down/step up should relate to some architectural feature (such as lining up with a window or change in wall direction). (See sketch – this page.)

If necessary, the *unit* must be excavated to minimize elevated slabs, front porches and driveways. Substantial backfill around the slab creating unnatural finished grade conditions is not an acceptable means to reduce exposed foundation sides, and shall not be allowed, nor is excessive dropping of *Masonry* or *Stucco* ledges.

On all *Masonry* or *Stucco* residences visible from a street or golf course, where the foundation (side/rear) exceeds six feet (6') from finished floor to natural grade, additional screening of foundation is required in the form of at least two of the following options: (i) a brick or stone wainscoting, (ii) *Masonry* planter boxes as defined, (iii) decorative *Stucco* banding/arches with layered landscaping as defined and/or (iv) wood (or other approved material) decks.

Masonry and *Stucco* Residences adjacent to a greenbelt, preserve or other unit, and not visible from a street or golf course where the foundation exceeds 6' from finished floor to natural grade, additional screening

of the foundation is required via the installation of a wood deck (or other approved material). The deck must extend across at least 1/3 of the rear width of the residence.

Options to screen the foundation must be submitted for approval to the AC with the plot plan application.

If planter boxes are chosen to screen foundation, the planters must be of a matching or compatible building material (see sketch on previous page), and may not exceed 4' in height. If the screening area requires more than 4' of screening, then the planter boxes must be tiered so as not to exceed the 4' height requirement.

Layered landscaping is defined as: a minimum of two layers of plants (1 layer of woody evergreen shrubs and 1 of perennial color) planted at the foundation or along planters.

Intent: to reduce large blank building walls. A large building mass can be reduced by adding planter walls and/or decorative banding (arches, recessed ornamentation); and/or planter walls with layered planting beds (see above).

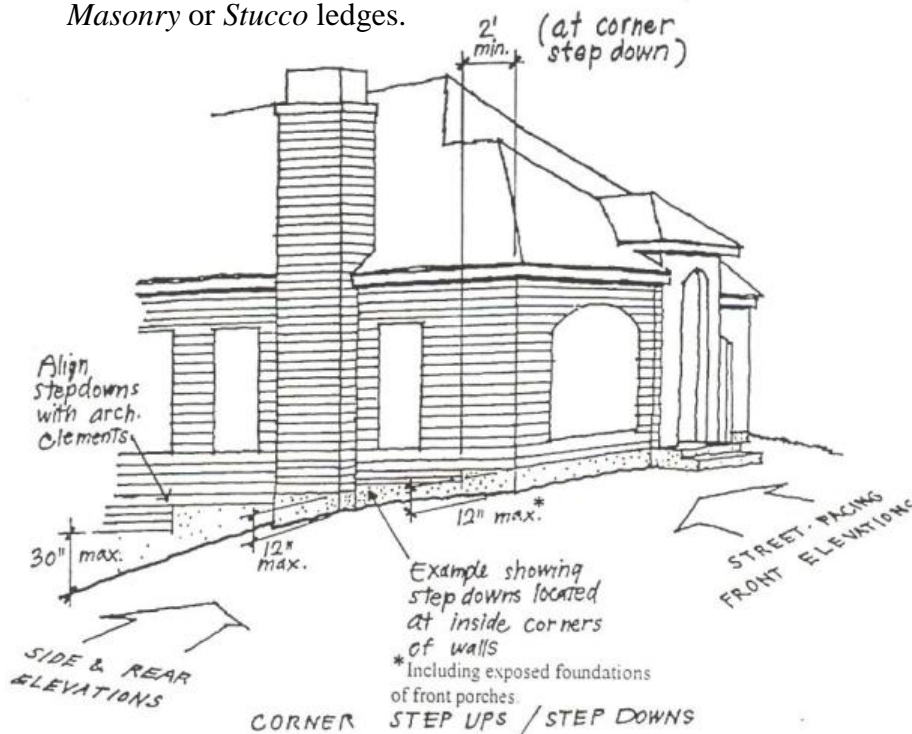

6.3 Height Limits

Goals:

Building should be of a compatible height profile throughout Steiner Ranch to promote a residential character.

VIEWS ARE NOT GUARANTEED, PRESERVED, OR PROTECTED IN STEINER RANCH.

However, promoting scenic views from the maximum number of existing and proposed building sites is a Steiner Ranch goal.

Requirements:

Building height must not exceed thirty-five (35') feet in height as measured from finished floor of the living area and may not be more than two stories, unless specifically approved by the AC.

Guidelines:

Building heights will be determined in a manner, which enhances an overall residential quality, while maintaining compatible relationships with adjacent *residences* and street frontages.

Building heights should be responsive to building heights on *units* located on slopes above and below the *residence*.

Scenic view compatibility should be considered in determining building location but again, **view protection is not guaranteed. Neither the Declarant nor the Homeowner's Association has a duty to protect a specific view.**

Sight lines, which are encouraged:

- Views to Lake Travis and Lake Austin.
- Views to distant undeveloped hills.
- Views into the greenbelt.

Within each neighborhood, a combination of one, one and a half, and two story *residences* is encouraged to add diversity to the streetscape.

For multilevel *residences* on corner *units*, consider locating the one-story portion of the *residence* at the street corner to help reduce the feeling of enclosure in the neighborhood.

A two-story *residence* can best relate to a neighboring one-story if it contains a one-story element.



Good Example of Optimizing Sight Lines

6.4 Roofs

Goals:

Roof profiles and roof treatments are to be visually integrated into the overall Steiner Ranch design concept. Therefore, careful consideration is to be given to roof design elements.

Roofs often are the dominant visual element in neighborhoods that have hilly terrain. They can also be dominant in a cluster lot neighborhood where the *residences* are closely spaced.

Requirements:

Roofs must be an earth tone color. A **range** of earth tone shades in each neighborhood is recommended. Roofs in primary colors are prohibited.

Roof venting stacks, piping, and other penetrations or other appurtenances must not distract from the overall roof elevation appearance.

Projections must be trimmed square and clean. Lift top turbine style ventilators are acceptable if they are not visible from streets, adjoining *residences*, or any other portion of the property subject to the Declaration.

All roof projections must match the color of the surface from which they project or must be an approved color.

Gutters and downspouts must be a complimentary color to the exterior materials on the house, to blend in and not be as visible.

The solar collectors and skylights must be submitted to the AC for review and approval before installation.

Solar Panel Requirements

All solar panels must be reviewed for approval, based on design and location, but at minimum must meet the following requirements:

- The glass, frame, flashing, and other solar panel collector materials must blend with the roof.
- All meters, disconnects, conduits, and other appurtenances must be painted to blend with the exterior of the house where attached
- Solar panels must not overhang the edge of the roof

Flat roofs and domes prohibited - Use gable and hip designs

Complex roof lines encouraged to create variety and interest

Mix a variety of earth tones to give neighborhood a natural and individualistic character



6.4 Roofs

- Location of panels, meters, disconnects, conduits, and other appurtenances must be submitted to the committee for review
- Solar panels should be located on an interior roof side, or rear facing roof side, when not abutting a street. Street facing locations may be considered when interior roof orientations have minimal sun exposure. All street facing locations will be reviewed on a case-by-case basis and may be reviewed by the AC with a variance.

The flat-glass type skylights are acceptable, but must not exceed ten per cent (10%) of the entire roof area. “Bubble” or dome type skylights will not be allowed. The glass, frame, flashing, and other skylight materials must blend with the roof.

Roofs must have pitched slopes that have a residential quality. Minimum roof pitch is 5 to 12. Maximum roof pitch is 12 to 12. Flat roofs and mansard roofs are prohibited; gable and hip roofs are the only permitted roof forms. Lower pitches for accent elements may be allowed if complimentary to overall design, and must be

submitted to and approved by the AC.

Acceptable Roof Materials:

All roof material must be approved.

- 30 year minimum warranty laminated “Architectural” grade dimensional composition shingle.
- Concrete or clay tile.
- Slate.
- Metal, only with baked on non-reflective painted finish (no primary colors).

Prohibited Roof Materials:

Prohibited materials include, but are not limited to: asbestos, wood shakes, wood shingles, corrugated materials, and all types of reflective metals.

Guidelines:

A variety of rooflines is encouraged, both throughout the neighborhoods and on individual *residences*.

Consider varying both roof pitch and orientation. Complexity and variety will help to make an interesting streetscape.

Eaves and overhangs, designed to afford protection from the elements and provide shadow relief are encouraged.

All exposed venting, stacks, and piping should not penetrate the roof on any roof slope facing a street *residence* so that such devices are not visible from the street except as noted below:

- 1) In locations where the backside of the *residence* abuts a street, all exposed venting, stacks, and piping should penetrate the roof on interior side-yard facing elevations (where the roof design allows).
- 2) Fixed dormer attic ventilating devices.

Roof-mounted mechanical equipment should not extend above the highest architectural element or be mounted on any elevation facing the street. Flat panel solar collectors and skylights are allowed, provided these items are “in scale” with the building and do not create a visual eyesore.

All projections or fixtures mounted to our penetrating the roof should be minimized from view.

6.5 Chimneys

Goals:

Chimneys are important in the design of a residence because they are usually the tallest vertical architectural element, sometimes rising well above the peak of the roof. As such, chimneys should be carefully designed so they become a positive feature of the residence's design.

Requirements:

All exterior and interior chimneys must be constructed of 100% of the following approved products (brick, stone, *Stucco*, or approved substitution, such as cement fiber board lap siding). Chimney must compliment the exterior material on the residence in color and material.

Chimney height must be designed as required by all applicable building codes and governing jurisdictions with regards to venting and fire safety.

Spark arrestors are required in all chimneys.

Guidelines:

Simple geometric shapes are encouraged, as well as chimneys projecting from the façade, as shown in figure below.

Consider overhanging trees when designing and locating chimneys. Provide an adequate setback from tree limbs to prevent damage to the tree canopy.

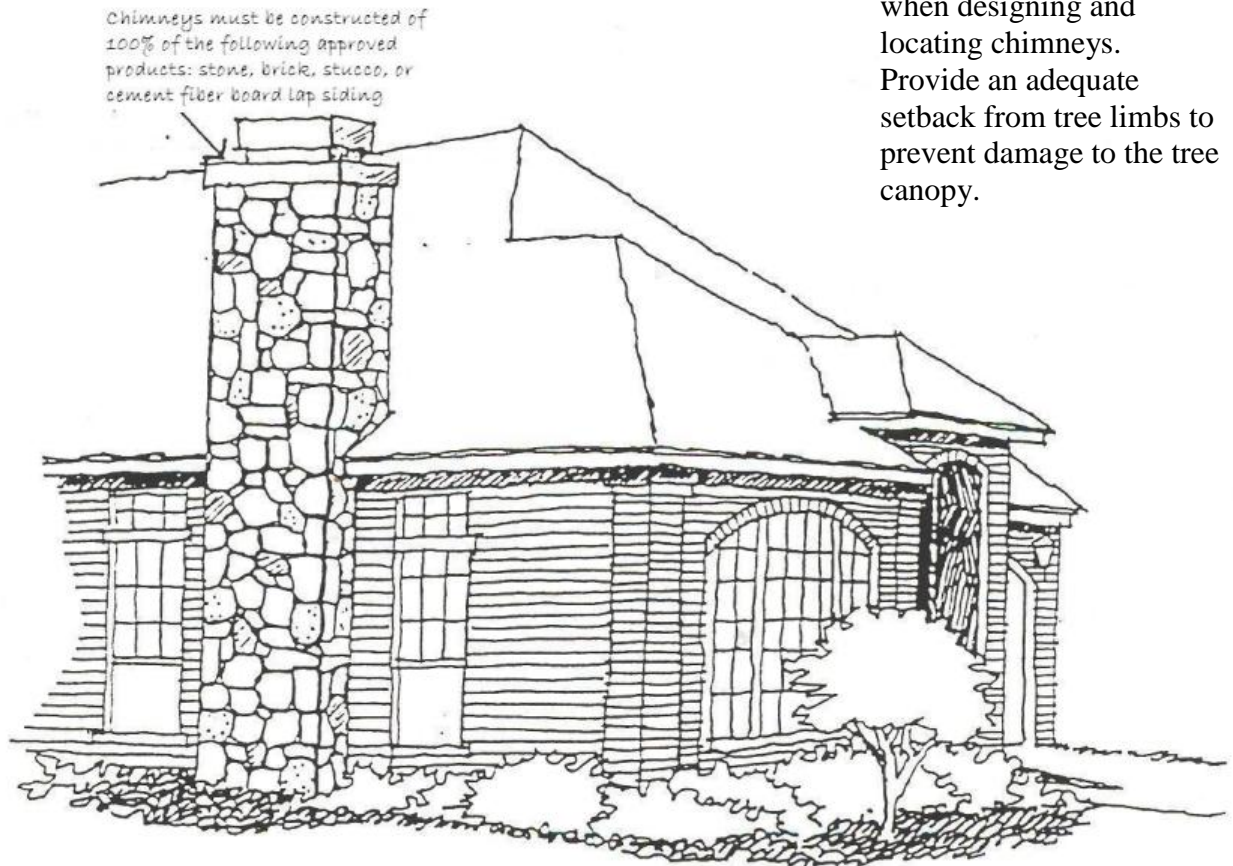

6.6 Garages

Goals:

Minimizing the visual impact of garages.

Requirements:

Garages must be designated to accommodate a minimum of two (2) full-sized sport utility vehicles. Recommended size for garage door openings is 9' wide x 8' high for single garage doors, and 16' wide x 8' high for double garage doors. Any doors over these dimensions must be submitted to the AC for approval.

Garage exteriors must be constructed of the same materials and have the same architectural style as the rest of the *residence*.

All garage doors must be of a sectional type with raised panels only, unless prior approval is given after architectural review.

Residences on corner *units* must be oriented so garages are located adjacent to the interior *unit* property line (away from the street corner). Side entry garages on corner *units* must be detached at the rear of the *unit* or placed at the end of the *residence* opposite from the street corner.

Side street entry garages must be set back a minimum of twenty (20) feet from the side street property line if there is a street sidewalk required on the subdivision plat.

Garages with more than two (2) car capacity are allowed based upon plan and site conditions. Cars, boats and/or campers must be kept out of public view. No more than two garage bays facing the front street is preferred, but in no case shall a residence have more than three garage bays facing the street.

Garages may be utilized as living areas or workspaces, if the plan has been submitted to and approved by the AC and sufficient space remains for two cars to be parked in garage. The appearance of a minimum of two garage bays must be maintained at all times.

Refer to specific Neighborhood Design Guidelines and Supplemental Conditions for additional requirements.

Guidelines:

Garages, whether detached or attached to the *residence*, should relate in a positive coherent manner. Side entry garages and detached rear garages are strongly encouraged on all *units* when possible.

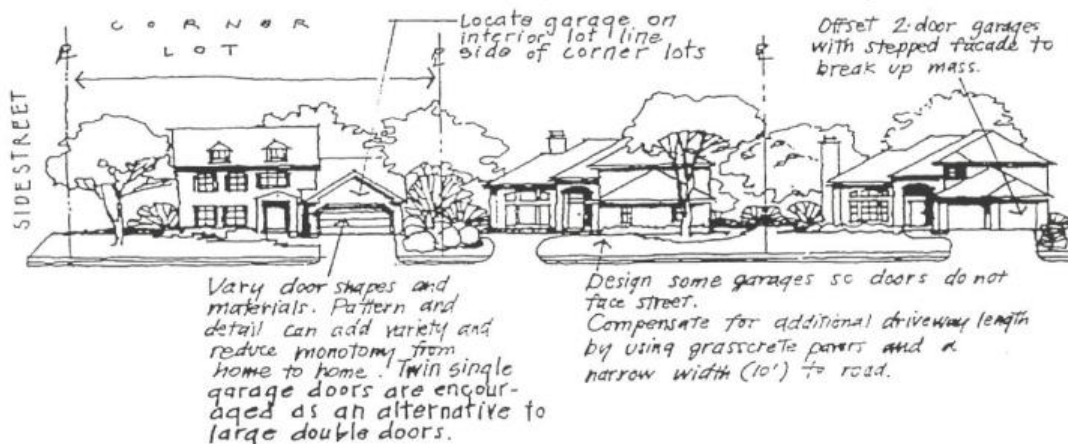

6.6 Garages

Detached garages located towards the rear of the *unit* are encouraged to vary the streetscape. Variances to building setbacks may be considered in order to help encourage detached garages. Setback adjustments will be considered on a case-by-case basis.

A variety of garage doors is encouraged in each neighborhood, including double doors and side-by-side single doors. Twin single garage doors are encouraged as an alternative to one large double door.

If three garage bays are facing the same street, then the variation of horizontal plane is encouraged to prevent one flat surface.

6.7 Energy Saving Features

Goals:

Keeping energy and depletable resources to an efficient and minimal use.

An important goal of Steiner Ranch is promoting harmony with the environment. Reducing energy demands assists in achieving this goal.

Guidelines:

Builders are urged to take part in the City of Austin's Energy Star program. Contact the City of Austin Environmental and Conservation Services Department, 499-3500, and Travis County Water Control and Improvement District #17, (WCID #17), 266-1111, for more information.

A minimum energy efficiency of two stars, as defined in the City of Austin's Energy Star program is encouraged. Refer to the diagrams below for additional guidelines.

Use of systems which shift utility demands (i.e., gas and electricity) to off-peak hours is encouraged. Recessed windows, overhangs, and the use of interior shading devices such as blinds are also encouraged.

Rooftop solar collectors and rain collectors are encouraged when they are integrated into the roof system or hidden from primary views (such as street-facing roofs). Both solar collectors and rain collectors must be submitted to the AC for approval. Please see the guidelines and requirements in section 6.4 Roofs for more information on solar collectors.

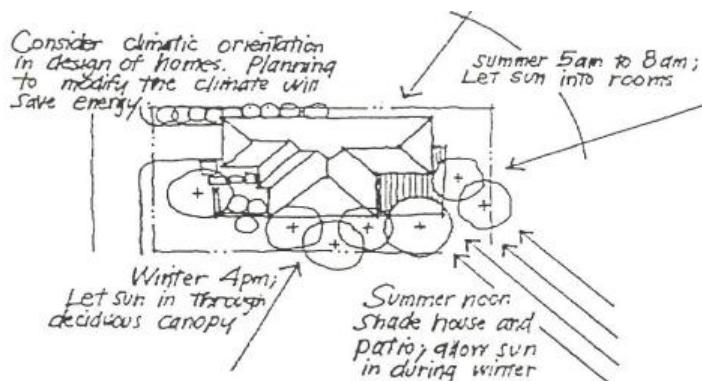
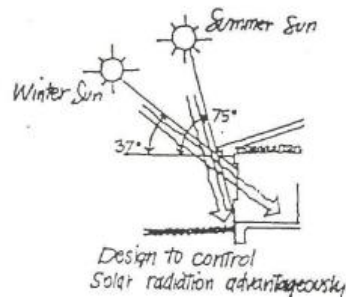

Energy Saving Recommendations:

Water heaters – use gas or heat pump fixtures with COP's of 2.5-3.
Insulation – walls should be R-19 (R-13 batts plus ¾" sheathing); ceilings should be a minimum of R-26 in sloped ceilings and R-34 in flat ceilings.
Heating/cooling system efficiency ratio (SEER) should be 13 +.
Air infiltration rate should be 0.7 to 0.9 air changes per hour.

Water Saving

Recommendations:
Showers: install ultra-low flow showerheads rate of 2.5 GPM.

Toilets: install ultra-low flush fixtures, which use 0.7 – 1.6 gallons per flush.

Install water efficient dishwashers.

Xeriscape Landscaping - see the Landscape Design Section 8.1.



Introduction:

Site design elements deserve careful consideration in their design and construction. Even a seemingly minor site detail is important as it may impact the entire *unit*.

Sections:

- 7.1 Driveways and Parking
- 7.2 Sidewalks and Entry Walks
- 7.3 Retaining Walls
- 7.4 Screening
- 7.5 Fences & Freestanding Walls
- 7.6 Site Lighting
- 7.7 Accessory Structures
- 7.8 Wood Decks

7.1 Driveways & Parking

Goals:

Minimize cars and other vehicles from dominating the streetscape zone.

Vehicle parking location and driveway design should be both functional and ancillary to the residential development.

Requirements:

Only one driveway and approach (20' maximum width) per *unit* is permitted on *units* with 100 ft or less of frontage. Double or circular drives must be submitted to the AC for review and approval before installation. In all cases, driveway must maintain at least 5' distance from side property line.

A minimum of 20' from front or side property line on single family residential units and from the edge of pavement on a private drive for condominium residences must be provided on the driveway without encroaching on the road or street sidewalk, in order to provide parking for two full-size cars. **Additional requirements for condominium parking may be found in the condominium guidelines, Section 10.**

Trailers, boats, campers, RVs, etc. are not permitted to be parked on the driveway or stored in public view.

Driveways and parking areas must be constructed at a minimum, with a textured finish; (i.e. broom or trowel finished

concrete). Driveways shall comply with the City of Austin driveway standard in Appendix. Asphalt driveways and parking areas are prohibited.

Refer to specific Neighborhood Design Guidelines and Supplemental Conditions for specific finish requirements.

The maximum driveway grade within the *unit* property is 14%. Driveway grades steeper than 14% must be approved. Refer to City of Austin driveway requirements for regulatory compliance. Driveways, sidewalks, and parking must meet the Americans with Disabilities Act requirements (ADA).



7.1 Driveways & Parking

Curbs must transition cleanly into existing street curb and gutter. “Broken” transitions between curb/gutter and aprons are not acceptable (See standard in Appendix).

Driveways must permit entry by standard mid-size vehicles without “bottoming out” in the transition area between curb and property line as well as the driveway area between property line and garage.

The finish grading process must conceal exposed edges of driveways and parking areas. A maximum of twelve inches (12”) vertical exposure is allowed at these surfaces.

Exposed foundations on driveways or walks up to twelve inches (12”) from finished grade must be finished with plaster, underpinning, or *Stucco* in a color that matches or compliments the color of the exterior *Masonry* of the residence. Any area of exposed foundation on driveways or walks exceeding twelve inches (12”) from finished grade must be faced with brick, stone, or similar material that matches or blends with the exterior colors of the residence. At their discretion, the AC may require additional screening with evergreen landscaping.

In situations where the driveway is raised 6’ above finished grade, the exposed sides of the driveway must be screened using additional fill and landscape planter areas with approved landscape plants (See Foundation, Section 6.2).

Guidelines:

Shared common driveways are allowed, subject to review and approval.

Exposed aggregate concrete (washed), stamped concrete, decorative *Masonry*, tile, or concrete pavers and/or banding is recommended.

7.2 Sidewalks & Entry Walks

Goals:

Sidewalk design which provides a functional and aesthetically pleasing means of pedestrian circulation.

Walks provide an important link between the driveway and the *residence's* front door as well as along public streets.

Requirements:

Sidewalks are required within the street (includes gated communities) right-of-way on certain units as designated on the subdivision plat. These sidewalks must be a minimum four (4') feet wide, with no more than 2% cross fall

(See exhibit this page), **must meet ADA requirements, and must have a broom-finish texture.** This includes sidewalks installed as part of the driveway. **Refer to specific Neighborhood Design Guidelines and Supplemental Conditions for additional sidewalk restrictions and guidelines.**

In general, the location of street sidewalks must provide for a minimum four (4') feet landscape-planting separation immediately behind the street curb. This separation shall be planted and maintained per Section 8.2, Installation & Maintenance, using plant selections from the Approved Plant List. Plant height must be maintained below 30 inches. Only

approved ornamental trees may be located in this separation zone. The City of Austin's sidewalk standard is located in the Appendix for reference.

Sidewalk curb ramps shall be installed at locations shown on the final plat according to the City of Austin's standard (See Appendix) and ADA requirements.

Sidewalks and entry walks must be constructed of broom or trowel finish concrete as a minimum level finish. See Guidelines for types of enhanced paving finishes.

Asphalt sidewalks are prohibited.

The *builder* is responsible for required street sidewalk construction by the completion of *residence* construction and prior to occupancy.

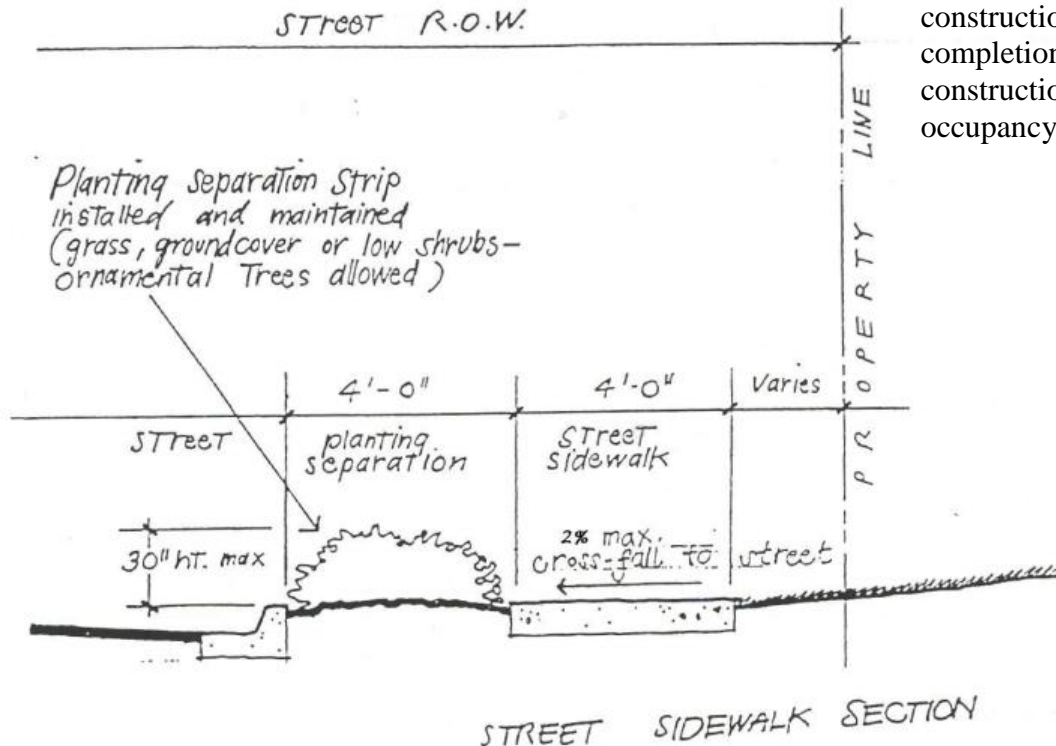

7.2 Sidewalks & Entry Walks

Entry walks connecting on-site parking and the primary building entry must be a minimum of 4 ft. wide.

If steps are necessary along the entry walk, they must occur in sets (or flights) with a maximum of 3' height for each flight of steps. A landing of 3-ft. minimum is required between sets of steps. Maximum riser height is 7 1/2".

Exposed foundations on sidewalks up to twelve inches (12") from finished grade must be finished with plaster, underpinning, or *Stucco* in a color that matches or compliments the color of the exterior *Masonry* of the residence.

Any area of exposed foundation on sidewalks/entry walks/stairs exceeding twelve inches (12") from finished grade must be faced with brick, stone, or similar material that matches or blends with the exterior colors of the residence.

In situations where the sidewalk is raised six feet (6') above finished grade, the exposed sides of the sidewalk must be screened using additional fill and landscape planter areas with approved landscape plants (See Foundation, Section 6.2).

Guidelines:

It is recommended that the primary entry to the residence be barrier-free design.

Accent paving materials, such as brick, exposed aggregate concrete, stamped concrete, concrete pavers, decorative *Masonry*, or tile as panels or tile as panels or banding, are encouraged to enhance the entry.

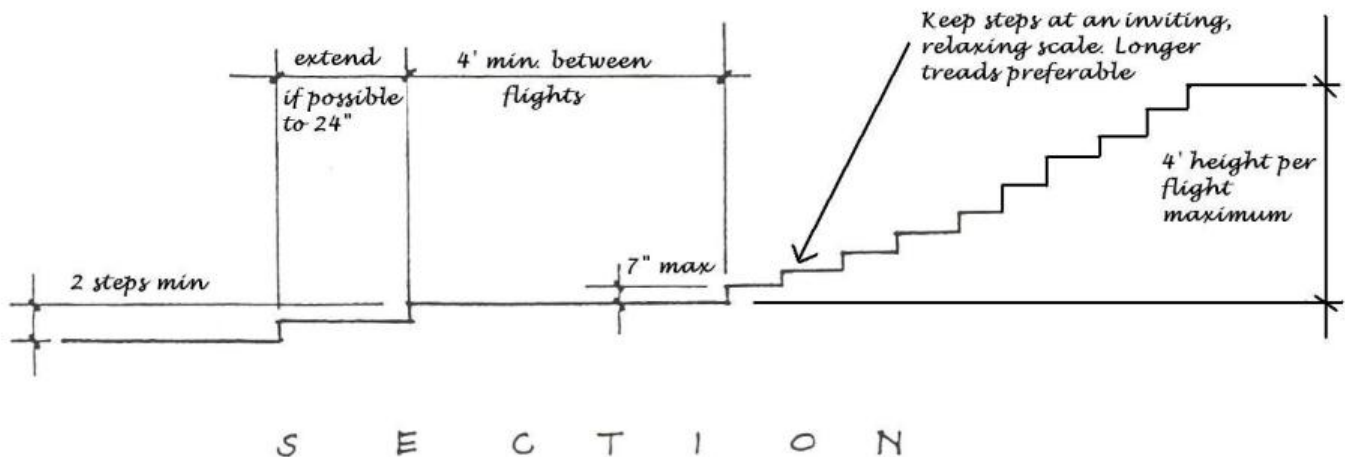

7.3 Retaining Walls

Goals:

The finished appearance of site walls should reinforce the Hill Country character.

Freestanding and retaining walls should provide a consistent appearance throughout Steiner Ranch.

Requirements:

All retaining walls must be native white limestone with a level, coursed, "dry stack" appearance, unless otherwise approved by the AC.

Limestone *Masonry* units shall be in the range of 4-6 inches in height, 12-24 inches in length, and 8 inches in depth, with broken face exposed surfaces and edges. Deep rake mortar joints of the stone walls to achieve a dry stack appearance.

Retaining walls are required at the street right-of-way when grade change exceeds 2 feet, and at all cut slope faces. If the grade change is less than 2 feet, then the builder/owner will be required to grade the lot to a natural slope of no steeper than 3 feet horizontal to 1 foot vertical. If a retaining wall is required at a vertical cut adjacent to the sidewalk, the placement of the retaining wall is encouraged to be directly adjacent to the

sidewalk, to prevent a "nuisance strip".

Retaining walls on a residential lot that runs parallel with any street shall not exceed 4' in height. Grade changes that require retaining walls exceeding 4' must be terraced with a minimum of 4' clear separation between each wall (See sketch next page). Provide a three feet (3") minimum (or per governing jurisdiction) planting separation strip between back of curb or sidewalk and face of wall. This planting separation strip must be planted and maintained with approved plant material (See Section 8.4).

If a retaining wall must be constructed in close proximity to a fire hydrant, the builder must comply with current code to insure enough clear space is given for fire hydrant use.

Benched areas must be planted and maintained with approved plant materials.

Walls within the public right-of-way must meet City of Austin and Travis County minimum design standards.

Walls must be adequately drained on the uphill side, if required. Please refer to Section 5.4 Grading and Drainage for more detailed requirements.

Guidelines:

Walls should be designed as an integral part of the residence and unit design. Stone block sizes should be consistent and laid in level horizontal courses.

Guideline examples are illustrated below and on the following page.

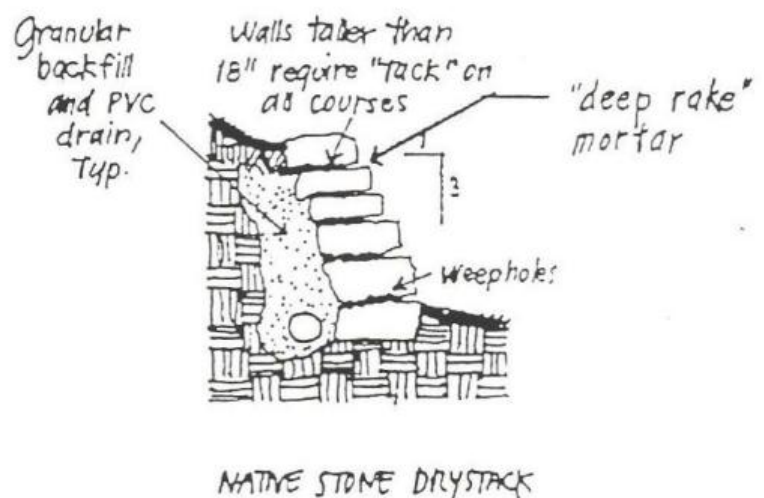

7.3 Retaining Walls

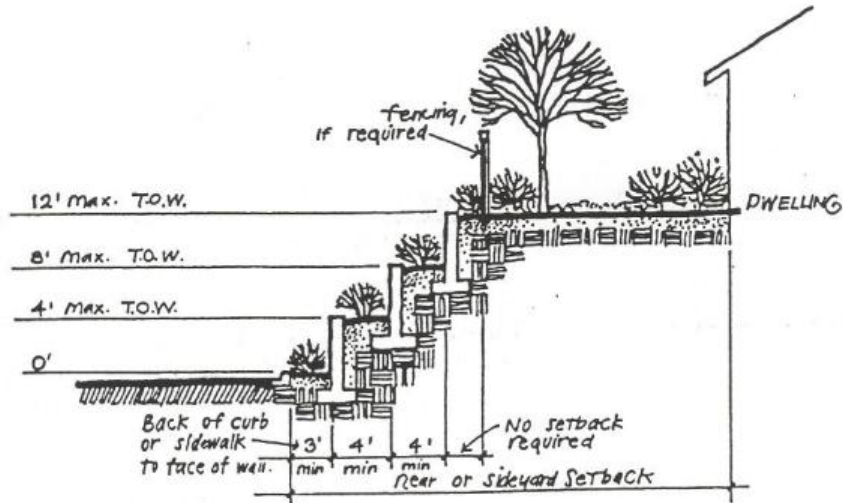

MULTI-WALL CONDITION

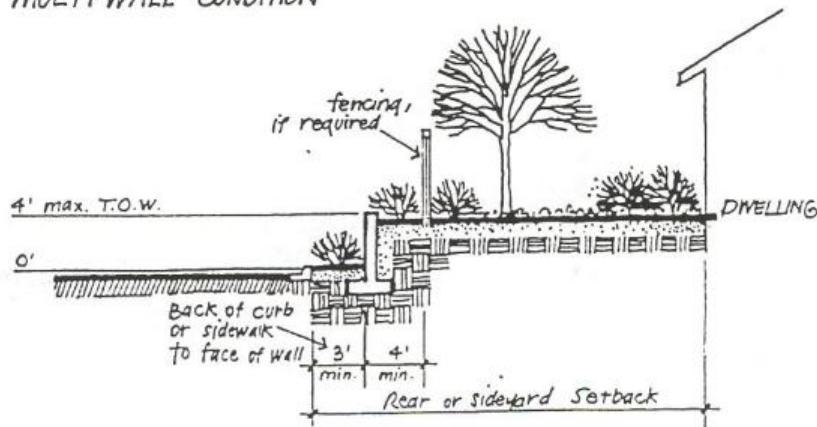

SINGLE WALL CONDITION

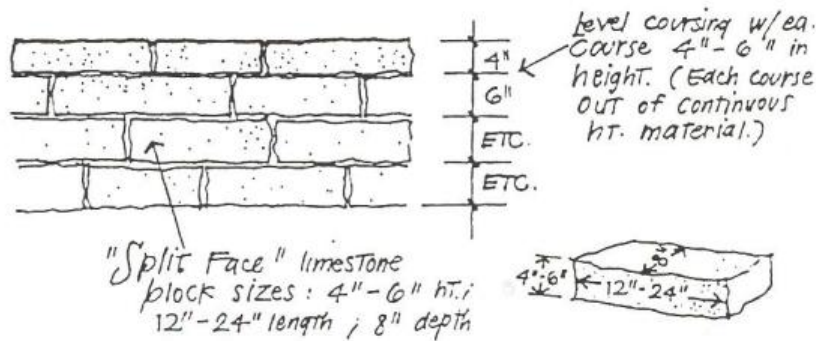

LIMESTONE MASONRY WALL ELEVATION

Note: The structural design, approval, and construction of all retaining and freestanding walls is the sole responsibility of the owner/builder. The diagrams shown above illustrate suggested wall construction finishes only.

7.4 Screening

Goals:
Shielding unsightly areas from public views.

Requirements:
Areas that require screening include, but are not limited to transformers, utility pedestals, lift stations, meters, air conditioning units, back flow preventers, pool equipment, driveways over 3' in height, and garbage can storage areas.

Utility meters must be located on side or rear elevations of the residence.

The meters, if visible from the street, must be screened with shrubs. If it is not feasible to screen the meter with shrubs, it must be painted to match the color of the surface to which it is mounted. All meters on sides of residence must be painted to match the exterior materials of the residence.

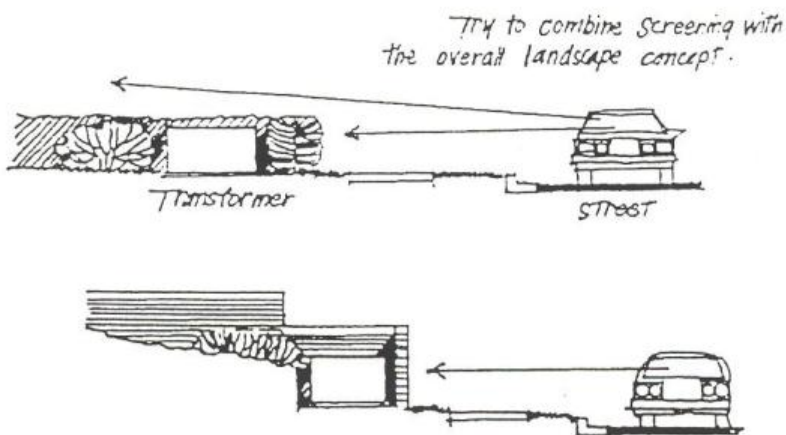
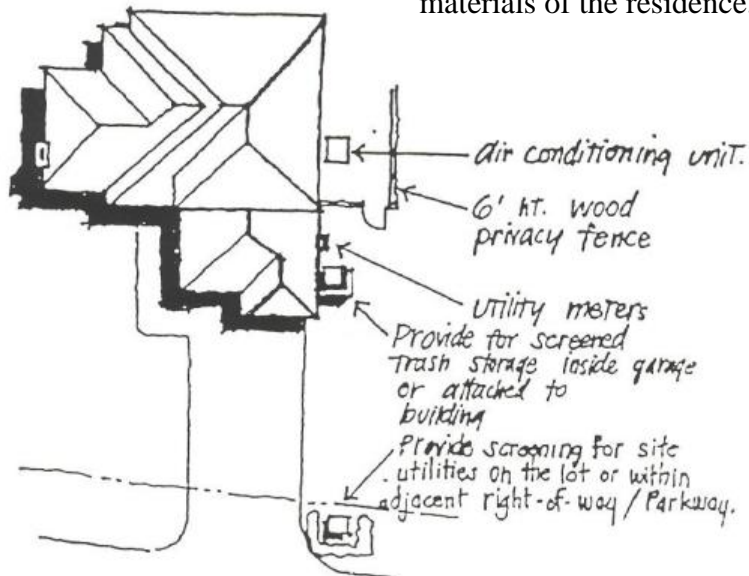

Evergreen shrubs, which are 18''-24'' at installation (5-gallon) and reach 4'-5' height at maturity, must be used to screen utility boxes that are within twenty (20) feet of the curb. Approved plant material would be elaeagnus, viburnum, lorapetalum, or cotoneaster. Any other plant material must be approved in advance by the AC.

All trash, rubbish, refuse and recycling containers, and trash cans must be screened from view of adjoining streets, residences, or other property subject to the Declaration by being stored in a garage, behind a solid fence or wall, or by another method that has been approved by the AC. **Refer to specific Neighborhood Design Guidelines and Supplemental Conditions for additional screening requirements or guidelines.**

If on steep sloping units with Masonry edge step-downs, electric services and HVAC piping is exposed more than four (4) feet above finished grade the piping must be painted a complimentary color to the exterior Masonry or Stucco of the residence. Owners/builders must screen utility meters and air conditioning units with the use of walls, fencing or plant materials upon completion of the residence before

7.4 Screening

occupancy. (See Landscape Design, Section 8.1, if using plant material as screening). If wood fencing is required in the neighborhood, the air conditioning unit must be located behind the fence. If no fence is required, an “L”-shaped wall is recommended, but at minimum the air conditioning unit must be screened with approved landscaping. **Refer to specific Neighborhood Design Guidelines and Supplemental Conditions for specific fencing requirements.**

Pool equipment must be screened with a wall or fencing, as approved by the committee at pool review.

Note: Boats, RVs, trailers, and other similar items must be stored in the garage or stored off-site.

Guidelines:

Items requiring screening (see above) should be located on the rear or side yards when possible. These elements should be integrated into the *unit* design.

Methods of screening include the use of plant material, architecture (i.e., building placement or using wing walls), free standing

walls, fences and earthen beams.

When plant material is used for screening, the material should be included in the overall landscape design and should be of an evergreen nature to provide screening year around. Screened areas should be adequately ventilated.

Please see section 10. Condominium Guidelines for screening requirements in a condominium community.

7.5 Fences, Gates & Walls

Goals:

Fences, gates and walls designed for separation of functional activities, screening, and privacy.

Fencing and walls should either be located such that they are unobtrusive or designed as an integrated and complimentary architectural design element.

Requirements:

Fencing Requirements

Fencing *improvements* are defined as: 1) the construction and installation of the fence and appurtenances, as well as 2) removal or alteration of an existing fence.

Fencing requirements may vary from neighborhood to neighborhood. **Refer to specific Neighborhood Design Guidelines and Supplemental Conditions for specific fence requirements and guidelines.**

The AC must approve all Fencing *improvements*, which differ from the standard approved fencing. Such submittal and approval shall include, but is not limited to, approval of the design, details, heights, material selection, and color selection (paint or stain).

Prior to the occupancy of a *residence* constructed on a Lot within the Property, a wooden (cedar or redwood), vertical slat, privacy fence, with no gap between slats, and no access gate from rear or side property fencing, shall be constructed to enclose the backyard.

Permanent fencing must be installed on lots adjacent to greenbelt, park sites, preserve areas, or golf course lots immediately after clearing and prior to foundation construction. No gates allowed in fences between unit and open space.

The fence shall not extend nearer to the front street than 2 feet behind the front wall of the principal building, not more than twenty (20') from the front corner of the home, and not nearer to any side street than the minimum set back line. Any fence to be constructed on a Lot, other than the required fence, requires the prior written consent of the AC.

Chain link fencing is not permitted except in areas specifically required by governing agencies or as originally constructed and installed by the Developer. As an exception, chain link fencing is permitted at tennis courts, lift stations and major water or wastewater infrastructure apparatus, but

must be appropriately screened with approved fabric, mesh or landscape screening.

No plastic or wire fences are permitted.

Lots, which abut a "greenbelt" area along the rear property line, may choose to install wrought iron fencing in place of the approved wood fencing, without prior approval from the AC. This applies to the rear property line only. Side and front fencing requirements remain the same.

Fences abutting a street, or which are visible from a street, permanent open space, or greenbelt area must be constructed with the finished side facing the street or open space. These fences may be double-faced.

Fencing which abuts major thoroughfares (as determined by the AC) must be coordinated with, and approved by the AC prior to installation.

The AC may, in its discretion, prohibit the construction of any other proposed fence or require that any other proposed fence be screened by vegetation or otherwise so as not to be visible from other portions of the Property.

7.5 Fences, Gates & Walls

A fence may not be located within a front or side street building setback (variances will be considered on a case-by-case basis).

Approved front or side street facing fencing located outside the building setback line does not require screening. Fences within a side street setback will be considered as a variance if a landscape plan is submitted and approved indicating the installation of “screening”

plant material (See Landscape Design, Section 8.1). All fence and planting improvements within the R.O.W./setback are at owner/builder risk and subject to removal.

Wherever a variance has been granted, an angled corner fence is required in locations where the fence extends beyond the building setback line and “returns” to a rear yard property line (See diagram, Landscape Design, Section 8.1).

The plot plan must show the fence location and indicate the method that the fence will be screened with existing or proposed plant material to soften the visual impact of a fence in close proximity to the street.

It is the responsibility of the *owner/builder* to ensure adequate visibility for vehicles looking beyond the fence and landscaping.

Fences within front yard setbacks must be approved by the AC.

Gate Requirements

Gates must be constructed of the same materials as the fence it is being installed in. Decorative or ornate hardware on the gate must be submitted to the AC for approval.

Gate openings are limited to a single gate not to exceed 4’ in width or a double gate not to exceed 7’ in width. One gate opening will be allowed on each side of the residence. No gates will be allowed into Greenbelts or Open Space areas.

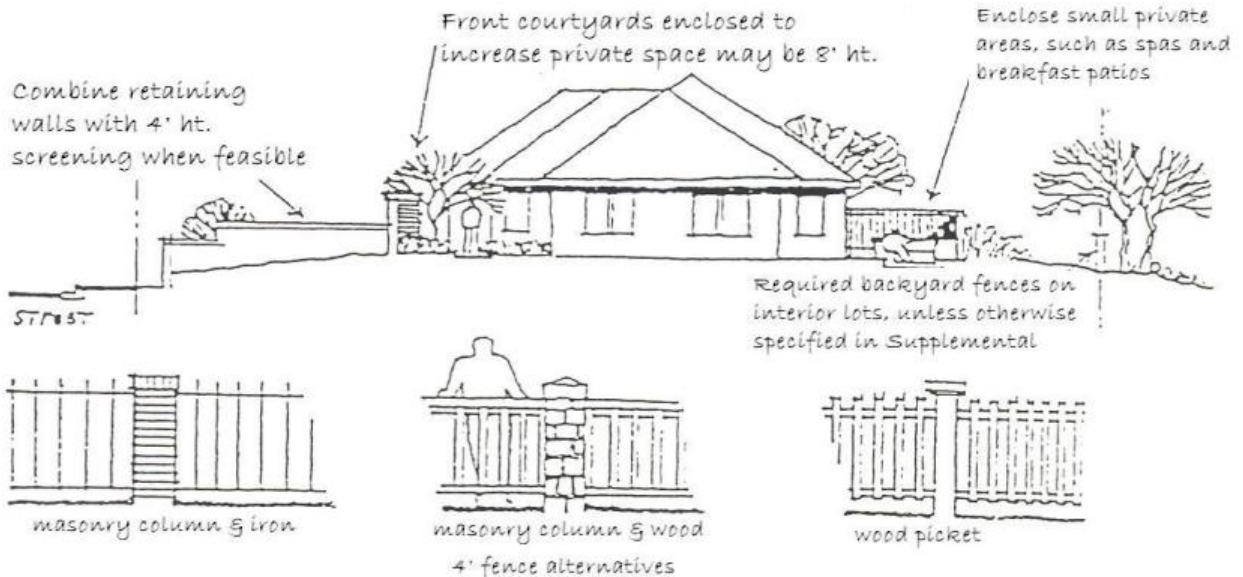

7.5 Fences, Gates, & Walls

Wall Requirements

All freestanding walls must be approved by the AC. Submission of a Modification Application is required in every instance. Each application will be assessed on a case by case basis.

Walls, courtyard walls, and/or wastewater lift station walls may not exceed six feet (6') in height without further approval from the AC. Walls that project in a way to reveal their thickness must return or terminate with a 12" x 12" minimum column. Walls must also be constructed of complimentary materials colors to the residence.

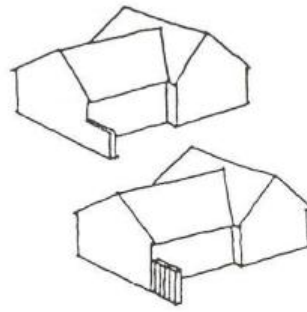

In general, low walls should duplicate building wall materials

A 2' minimum offset must be used when a fence is not an integral part of a wall.

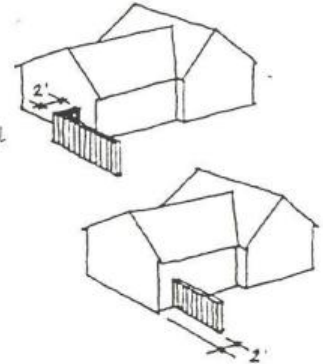

Walls that project in a way to reveal their thickness on primary elevations must return or terminate into a 12" minimum appearance

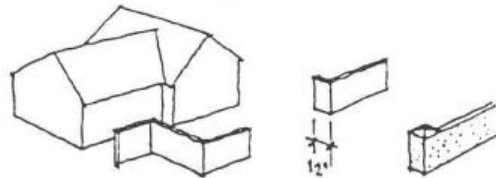

7.6 Site Lighting

Goals:

Site lighting should compliment and reinforce the residential quality of Steiner Ranch.

Requirements:

All *residence* entries shall be adequately lit. The AC must approve all lighting.

Lights must be positioned and properly hooded towards the *residence* or *unit's* yard so that light does not spill over into a neighbor's property, public areas, or face into street rights-of-way. All security or floodlighting attached to *residences* must be screened or shielded so that the light source is not visible from neighboring *units*. If the fixture is to be mounted directly to the wall of the structure, then it must blend with the existing material on the wall. No galvanized fixtures will be allowed.

Tennis court or sport court lighting is not permitted (except for courts in Common Areas).

The color of entry and landscape lighting must be white or off-white. No primary color lenses or bulbs shall be used.

Pole mounted floodlights are prohibited. High intensity lights are prohibited. Front

yard residential scale coach or lamp type fixtures are encouraged.

Guidelines:

Choice of fixtures should reflect the design theme of the *residence* and the overall design character of Steiner Ranch.

Courtyards and outdoor seating areas should be lighted to promote pedestrian use.

Above-grade junction boxes for walk lights placed in grass areas or adjacent to walkways in shrub or groundcover areas may be used provided the boxes are hidden from view by shrubs or landscape means.

Lighting variety is encouraged to create design interest in conjunction with the character and lighting function.

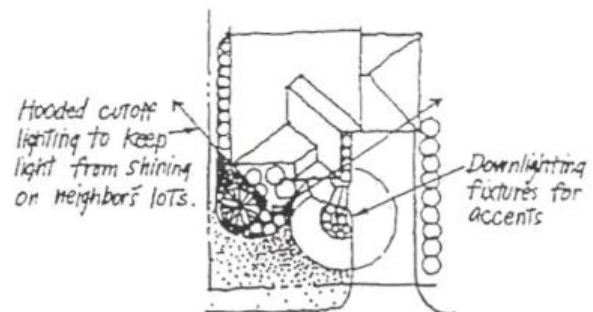
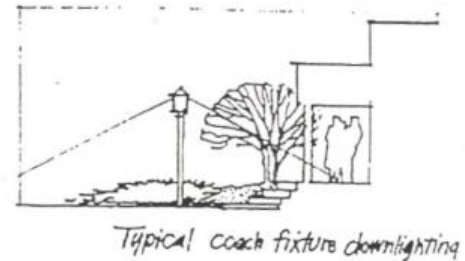
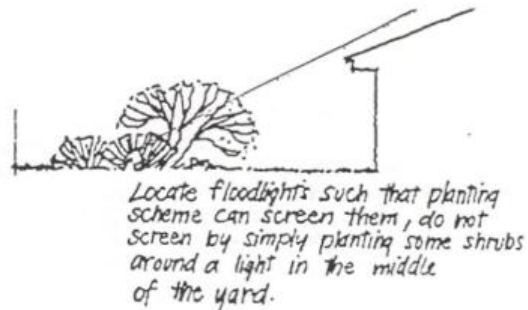

7.7 Accessory Structures

Goals:

Accessory structures designed for miscellaneous uses should be screened, not visible, and architecturally pleasing.

Requirements:

Examples of accessory structures include storage buildings, rain collectors, playscape structures, gazebo and trellis structures, outdoor kitchens, outdoor fireplaces and firepits, and trampolines. These structures are not permitted in the front yard of *units*. Views of these structures installed on corner lots must be reduced from public streets and adjoining *units*, and may require additional screening to soften the appearance at AC's discretion. Locate accessory structures so vegetation and/or slope conditions help in screening it from the street and adjacent lots. Treehouses are not permitted.

Owners/builders must receive approval before installing any accessory structure on their *unit*. Please see the modification application for specific submittal requirements.

Accessory structures must not be located any closer to a property line than the established building setbacks. In general,

accessory structures must be a minimum of five feet (5') from the side and/or rear property line. **Refer to specific Neighborhood Design Guidelines and Supplemental Conditions for additional setback restrictions.**

Playscape Structures:

Playscapes are reviewed on an individual basis by the AC, but the following requirements should be kept in mind when designing or selecting your playscape:

 The primary material for the playscape structure must be constructed with a lumber that resists rotting and deterioration, i.e. redwood or treated lumber. Metal playscapes and swingsets are prohibited.

 Canopies on the playscape must be a solid color, preferably green or earth tone.

 Setbacks for playscapes up to 10' in height are to be no less than 5' from each side and/or rear property line. For playscapes, which exceed 10' in height, the portion over 10' in height can not be any closer to side and/or rear property lines than 10', while the remaining portion under 10' in height shall be no less than 5' from side and/or rear property lines. Additional screening may be required, at the discretion of the AC. Playscapes in rear or side yards adjacent to the Golf Course may not be installed any closer to the rear property line than twenty five feet (25').

In all cases, the playscape can not exceed 15' in height.

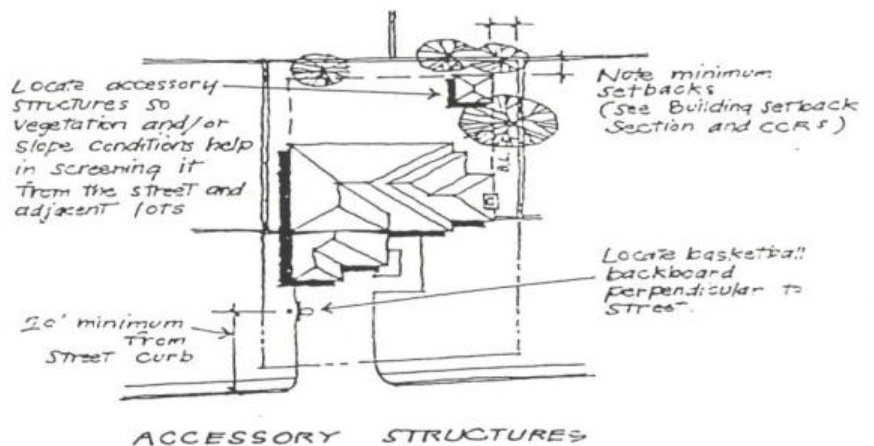

7.7 Accessory Structures

Storage Structures:

Accessory storage structures and above ground rain collector storage structures may be constructed only with approval. The AC, prior to installation, must approve design and location of storage structures.

Storage structures must be residential type construction with roofing, paint color, and other construction materials and details that match the *residence*. Vertical siding is prohibited. The peak of the structure shall be a maximum of eight feet six inches (8'6") from the ground and the sides a maximum of six feet (6') above finish grade.

Storage Structures may not be erected any closer to the property line than five feet (5'). Storage sheds in lots adjacent to the Golf Course may not be erected any closer to the rear property line than twenty five feet (25').

Maximum storage structure size is 8' x 10'. Metal and "barn-like" storage structures are prohibited.

Miscellaneous Structures:

Solar panels will be reviewed on an individual basis. Please see Section 6.4 Roofs for detailed requirements.

Non-Portable basketball goals are permitted in the front yard provided they are located a minimum of 20 ft. from the back of street curb. The backboard attachment to the roof or other parts of the home is **not** permitted. A single portable basketball goal is allowed provided it is stored in the residence's driveway no less than 20 feet from the back of curb.

Trampolines, whether portable or non-portable, must be placed no closer than 10' to any property line. Trampolines are not allowed in the front yard.

Patio covers and greenhouses must be of a high quality approved material, specifically designed for that use, and approved prior to installation.

All pool and/or spa construction, including equipment, fences and gates, must be in conformance with standards imposed by the local governmental agency and approved by the AC. All pool drains must be constructed in accordance with applicable local government standards and may not drain into or across Greenbelts, Common Areas, Open Space areas or adjacent *units* without written AC approval.

The Pool height may not exceed six feet (6') above natural grade. Pool Accessory Structures, i.e. waterfalls, grotto slides, slides and caves may not exceed six feet (6') in height above natural grade.

The pool, spa, patio or pool accessory may not be erected any closer to the property line than five feet (5'). Pools or spas in lots adjacent to the Golf Course may not be erected any closer to the rear property line than ten feet (10').

For covered accessory structures (i.e. Cabanas, Arbor/Pergolas, Palapas, etc.) which exceed 10' in height, the portion over 10' in height can not be any closer to any side and/or rear property lines than 10', while the remaining portion under 10' in height shall be no less than 5' from any side and/or rear property lines. Covered accessory structures (i.e. Cabanas, Arbor/Pergolas, Palapas, etc.) in lots adjacent to the Golf Course may not be any closer to the rear property line than twenty five feet (25').

Additional screening may be required, at the discretion of the AC.

Above ground pools are prohibited.

7.7 Accessory Structures

Firepits/fireplaces and outdoor kitchens must be constructed of materials that are complimentary to the main structure, and must be approved in writing by the AC. Outdoor fireplaces and kitchens are limited to fifteen feet (15') in height maximum, but must also be in scale with the house.

Propane tanks for additional heating to pools or other uses will be reviewed on an individual basis. However, in no case will the tanks be allowed above ground.

Flagpoles:

For flagpoles six feet (6') in length or shorter, the following guidelines apply:

- (1) The pole may be mounted on the house or garage on a permanent or temporary basis.
- (2) A temporary flagpole may be placed in the ground and kept there only when the flag is displayed.
- (3) The flag may not exceed three feet (3') by five feet (5') in size. Only official flags of countries, schools, sports teams, and seasonal decorative flags may be displayed. Flags which display trademarks or advertising, and battle flags and similar flags that, in the judgement of the AC, are

intended to, or tend to, incite, antagonize, or make a political statement (other than a statement of citizenship or country of origin of the residents' home), shall not be permitted.

(5) If evening display of the flag is desired the house mounted flag may be lit from the base of the flagpole (maximum of two bulbs) with a total of no more than 150 watts. The light must shine directly up at the flag, and cannot cause any type of light spillage onto adjoining properties.

(6) Both the house mounted and in-ground flagpoles must be removed from view when no flag is displayed.

(7) All flags and flagpoles must be properly maintained at all times, including, but not limited to: replacement of faded, frayed or torn flags; and replacement of poles that are bent, rusted or damaged in any way.

(8) Attaching flagpoles to fences or trees is not permitted. Flags cannot be displayed from fences or shrubbery. All proper flag etiquette must be followed.

(9) For all flagpoles six (6') feet in length or shorter, no submission for approval is necessary provided these

guidelines are followed.

Any installation of a flagpole or flag not in compliance with these guidelines will be considered a deed restriction violation and will be dealt with accordingly.

For all permanent and temporary in-ground flagpole installations, where the pole is taller than six (6') feet, the following guidelines apply:

The following guidelines have been developed to assist the homeowner in complying with the above requirement of the deed restrictions. A modification application must be submitted for review to the AC for all permanent and temporary flagpoles taller than six feet. Formal approval from the Committee will be required before installation may begin.

(1) Only one pole is permitted and one flag (either the United States or Texas) may be flown from this pole.

(2) Permanent in-ground flagpoles are generally defined as those that are installed in an appropriate footing (usually concrete) and are not meant to be

removed unless the flagpole is being replaced. Temporary in-ground flagpoles are generally defined as those poles that are installed in the ground by a sleeve system that is designed to allow the easy removal and reinsertion of the pole.

(3) The tops of permanent or temporary flagpoles may not be lower than fifteen (15') feet or taller than eighteen (18') feet when measured from ground level (including the pole ornamentation). The size of the flag must be appropriate for the height of the flagpole, but in no case larger than 3' x 5'.

(4) Flagpole halyards must be of a type which does not make noise under any wind conditions. Halyards must be securely fastened.

(5) Poles must be mounted on an appropriate footing and if this footing is visible, it must be screened with adequate landscaping. All flagpoles must be installed per the manufacturer's guidelines.

(6) The pole may be white, silver or bronze. Pole material must be metal. The only pole ornament that will be permitted is a ball of the same material and color as the pole.

(7) The preferred location for

placement of the pole is within the landscape beds; however under all circumstances, flagpoles may not be placed more than ten (10') feet from the foundation of the house (residential structure, not from the front of an attached garage). On houses that have a front yard fifteen (15) feet or less in depth, the pole may be placed in a position, equidistant from the house's foundation and the sidewalk. Poles may only be installed in front yards and within the established building lines. Poles must be installed in a manner that prevents obstruction of neighbors' views.

(8) If a flag is to be flown daily (from dusk till dawn) then a permanent pole may be installed. If a flag is only going to be flown on specific holidays (as per the Flagpole Etiquette Guidelines) or less frequent than every day, then the pole must be a temporary in ground pole and it must be removed from the ground on those days that a flag is not being flown

(9) If the flag is to be flown after dusk, it must be properly illuminated per the Flagpole Etiquette Guidelines. They may be lit with an in-ground light (maximum of two bulbs) with a total of no more than 150 watts. The light must

shine directly up at the flag. It cannot cause any type of light spillage onto adjoining properties.

(10) Only the United States and/or Texas flags may be flown on these flagpoles. (For all other type of flag displays- i.e. seasonal, decorative flags - please see the guidelines for flagpoles under six feet (6') in height).

(11) The flag and flagpole must be properly maintained at all times. Should the flag become faded, frayed or torn; it must be replaced immediately. If the flagpole becomes scratched, dented, leaning; or if the paint is chipped or faded, it must be replaced or repaired immediately.

Guidelines:

When approved for use, accessory structures should be carefully integrated into the *unit* design to minimize their negative visual impacts from the street frontage or adjacent *units*.

7.7 Accessory Structures



Satellite Dishes:





There shall be no requirement to obtain approval from the AC prior to installation with respect to (1) antennas designed to receive direct broadcast satellite service which are one meter or less in diameter; (2) antennas designed to receive video programming services via multi-point distribution services which are one meter or less in diameter or diagonal measurement; or (3) antennas designed to receive television broadcast signal.

Requirements:

The antenna/satellite dish shall not be installed in the front yard (pole mounted), on the front elevation (side mounted) of the residence or visible from the street or sidewalk.

Guidelines:

-  The attic, crawl space, garage, or other interior space of the Residence or another approved structure on the Unit so as not to be visible from outside the Residence or other structure; or
-  The rear yard of the residence (i.e., the area between the plane formed by the rear façade of Residence and the rear lot line) and setback from all lot lines at least eight feet (8'); or

-  Attached to or mounted on a deck or patio and extending no higher than the ridge line of that portion of the roof of the Residence directly in front of such antenna; or
-  Attached to or mounted on the rear wall of the Residence so as to extend no higher than the eaves of the residence at a point directly above the position where attached or mounted to the wall.
-  All associated cable must be run in straight, horizontal and/or vertical lines and be tightly secured every two feet to four feet (2'-4'). The cable is to be installed in such a way as to be as inconspicuous as possible. Cable runs contained within the residence are preferred whenever possible. Visible cable must match/blend with the background color where attached.
-  A completed modification application must be submitted to the AC for review after satellite dish or antenna installation, although submittal is preferred prior to installation.
-  If the location of the installed satellite dish or antenna does not comply with the above stated requirements, the AC may require relocation of

the satellite dish or antenna to meet the screening guidelines.

-  The satellite dish or antenna may be required to be painted to match the background it is attached to in order to help minimize the visual impact.

Satellite dishes or antennas that exceed one (1) meter in diameter are required to be submitted to the AC for approval prior to installation.

Please contact the Homeowner's Association prior to installation to submit the location and type of satellite dish/antenna to be installed.

7.8 Wood Decks

Goals:

Locating wood decks to be unobtrusive and designed as an integral part of the overall architectural and site design.

Requirements:

All proposed decks and materials on either new or existing *residences* must be submitted for approval. Please refer to the Deck Addendum found in the Appendix for submittal requirements.

Wood decks are not permitted in the front yard.

No deck shall be located closer to any property line than the building setback line, with the exception of rear yard. With prior approval, a deck may extend over the rear yard setback,

but under no circumstances shall a deck be closer than ten feet (10') to the rear property line. Uncovered porches or patios may also extend into the rear setback, but may not encroach into side yard setbacks.

Depending on the grade differential and the degree of public views to the deck location, the AC may require additional setbacks and height limitations other than those described. Additional modifications may also be required for approval. The elevation of decks must be no higher than the corresponding finish floor of the *residence*.

Second story decks will be evaluated on a case by case basis. Additional setbacks may be required, depending on the grade of the lot and the elevation of the deck.

Storage areas located under decks shall be adequately screened. The underside of ground floor decks must be screened using wood lattice or pickets (1" by 2" minimum) if the area below the deck is used for storage or when the height of the deck exceeds four feet (4') above finish grade. Other materials may be considered. Exterior *Masonry* or *Stucco* may be eliminated from areas under first floor decks that are screened with approved lattice or pickets.

Nothing may be stored under a deck or stairwell with out adequate lattice or landscape screening.

Guidelines:

The deck color should match or compliment the home color palette. Earth tones are encouraged. Primary paint colors are prohibited.

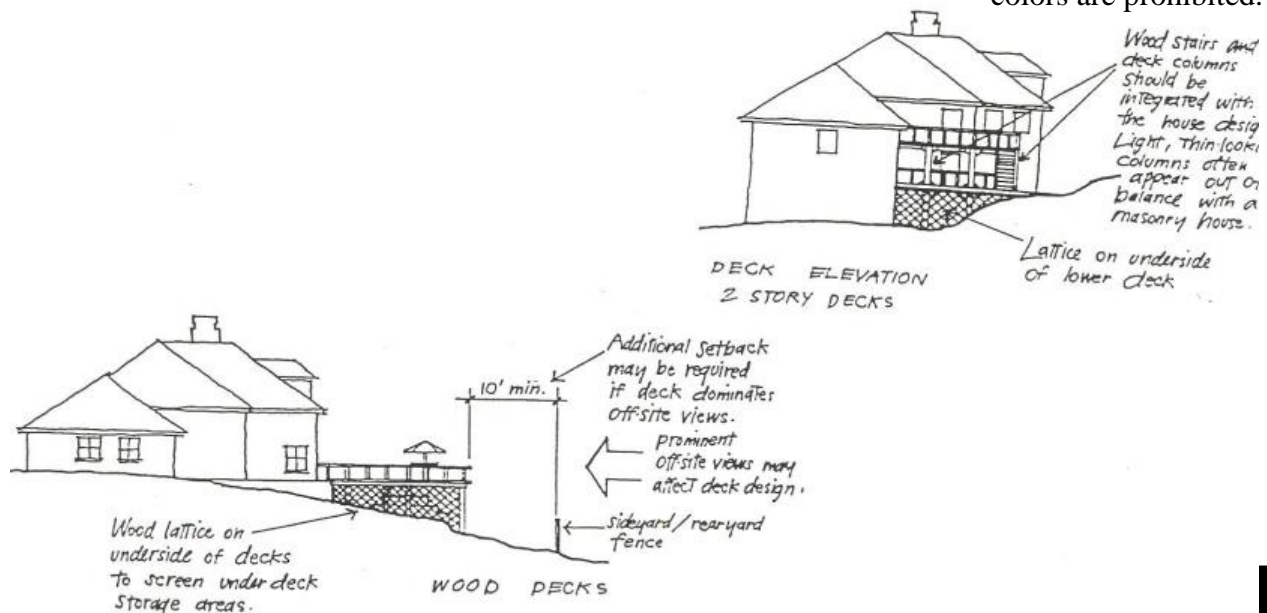

7.9 GREENBELTS

Goals:

To maintain and preserve the harmonious Texas Hill Country of the designated Native Areas, Greenbelts, Common Areas and Native Plant Life.

At no time will permission be granted to access the Balcones Canyonlands Preserve. Disturbance and access will be subject to all applicable fines as noted in the Fine/Fee List as well as subject to any Local and Federal jurisdiction.

Requirements:

Any clearing, tree removal, trimming/pruning, mowing or access must be submitted to the AC for review. Review will be on a case-by-case basis. No clearing, tree removal, trimming/pruning, mowing or access will be allowed in the Native Areas, Greenbelts or Common Areas with out written approval from the AC.

Guidelines:

Only the following trees, shrubs and/or grasses will be considered for clearing, tree removal, trimming/pruning, mowing or access. No variety of Hardwood tree will be allowed for removal at any time unless proven to be a non-viable tree or a

threat to the neighboring property by a Certified Arborist.

Only trimming/pruning of hardwood tree limbs will be considered if the limbs at any point have grown across the shared property line. "Limbing up" the Harwood tree could be considered if the limbs are below four feet (4') in height at the trunk and below six inches (6") in diameter or to "thin out" the dead branches from the canopy.

Cedar Juniper trees will only be considered for removal if the tree is non-viable or under four feet (4') in height, no larger than twelve inches (12") in diameter and within thirty feet (30') of the shared property line. Larger Cedar Juniper trees may be considered to "limb up" the smaller limbs below four feet (4') in height or "thin out" dead branches from the canopy.

At no time will a Hardwood tree or Cedar Juniper be "topped off", the top of the canopy must remain intact.

Shrubs may be considered for removal if the shrub is under four feet (4') in height, three feet (3') in width and within thirty feet (30') of the shared property line. Shrubbery may be

considered for trimming/pruning if the shrub has grown across the shared property line. Grasses may be considered for mowing if the grass height is greater than two feet (2') in height and no farther than ten feet (10') from the shared property line.

All branches, limbs, cuttings and brush must be removed from the Native Area, Greenbelt or Common Area and disposed of properly.

Chipping in the Native Area, Greenbelt or Common Area is not allowed.

Disturbance of the Native Area, Greenbelt or Common Area without prior AC approval will be subject to all applicable fines as noted on the Fine/Fee List.

Permission to access the Native Area, Greenbelt or Common Area for construction to a neighboring property is at the sole desecration of the AC.

8. Landscape Guidelines

Introduction:

The final step in completing the neighborhood setting in Steiner Ranch is the finished landscape. Proper site planning should preserve existing trees and large shrubs wherever possible, creating the basis for a landscape design that emphasizes the use of low maintenance, drought tolerant native plants. This “xeriscape” landscape can both enhance the appearance of the home and provide the homeowner with an energy efficient site.

Goals:

Combining the best of natural landscape with appropriate, carefully introduced landscape elements for the benefit of residents.

Xeriscape landscape design principles are encouraged in order to develop native and naturalized plantings, which are drought tolerant and suited to the local growing

conditions. For more information on how to design landscaping with xeriscape principles and techniques, please refer to the following websites:

- <http://aggie-horticulture.tamu.edu/extension/xeriscape/xeriscape.html>
- <http://www.greenbuilder.com/sourcebook/xeriscape.html>
- <http://www.ci.austin.tx.us/watershed/plantlist.htm>
- <http://www.hillcountryhome.com/deer-resistant.pdf>

Almost half of the water used during summer months is used in the yard. It is more important than ever to install landscape plant materials that use water efficiently.

Deer are a major landscape menace in the Steiner Ranch area. Few plants are fully deer-proof, but a number of species are unpalatable enough to be left alone as

long as other food is available. The approved plant list included in this section is composed primarily of “deer-resistant” species to discourage deer foraging.

Keep in mind that droughts and other environmental conditions that create a serious food shortage may cause deer to lose their inhibitions and eat even the most “deer-resistant plants.

Sections:

- 8.1 Landscape Design
- 8.2 Installation and Maintenance
- 8.3 Integrated Pest Management
- 8.4 Approved Plan List

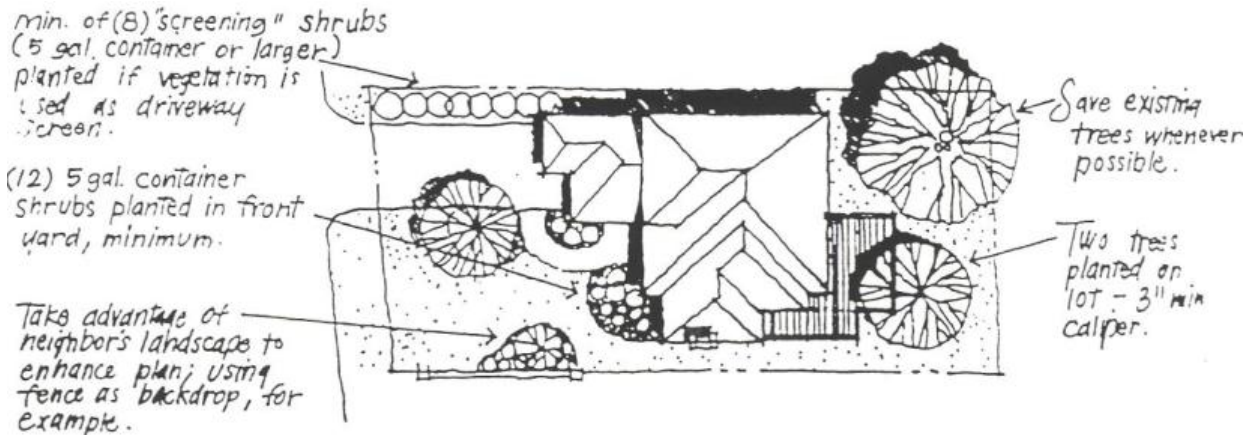

8.1 Landscape Design

Requirements:

Front yards and side yards – to the rear of the *residence* or to the face of the installed side yard fence – must be sodded within ten (10) days after occupancy to minimize soil erosion.

Install and maintain erosion controls as necessary in the rear yard (if unsodded) to prohibit runoff onto adjacent property, until landscape improvements are completed.

All landscaping must be installed by the *owner/builder* within six (6) months of builder completion or sale and closing on the purchase of the *residence*, whichever occurs first.

Landscape Requirements:

50' wide lots – The following are landscape requirements for lots, which are classified as fifty foot (50') lots: (i) minimum of two (2) three-inch (3'') trees, (ii) twenty (20) shrubs at a minimum of five (5) gallon in size, (iii) twenty (20) ornamental grasses, groundcover, or perennials at a minimum of one (1) gallon in size, and (iv) sod at minimum to the rear corner of the residence are required at each street yard.

60' wide lots – The following are landscape requirements for lots, which are classified as sixty foot (60') lots: (i) minimum of two (2) three-inch (3'') trees (ii) twenty-five (25) shrubs at a minimum of five (5) gallon in size, (iii) twenty-five (25) ornamental grasses, groundcover, or perennials at a minimum of one (1) gallon in size, (iv) sod at minimum to the rear corner of the residence are required at each street yard.

70' wide lots – The following are landscape requirements for lots, which are classified as seventy foot (70') lots: (i) minimum of two (2) four inch (4'') trees or three (3) three inch (3'') trees (ii) thirty (30) shrubs at a minimum of five (5) gallon in size, (iii) thirty (30) ornamental grasses, groundcover, or perennials at a minimum of one (1) gallon in size, (iv) sod at minimum to the rear corner of the residence are required at each street yard.

80' wide lots – The following are landscape requirements for lots, which are classified as eighty foot (80') lots: (i) minimum of two (2) four inch (4'') trees or three (3) three inch (3'') trees (ii) one (1) ornamental tree with a minimum of two-inch (2'') caliper, (iii) thirty-five (35) shrubs at a minimum of five

(5) gallon in size, (iv) thirty-five (35) ornamental grasses, groundcover, or perennials at a minimum of one (1) gallon in size, (v) sod at minimum to the rear corner of the residence are required at each street yard.

90' wide lots – The following are landscape requirements for lots, which are classified as ninety foot (90') lots: (i) minimum of two (2) four inch (4'') trees or three (3) three inch (3'') trees (ii) one (1) ornamental tree with a minimum of two-inch (2'') caliper, (iii) forty (40) shrubs at a minimum of five (5) gallon in size, (iv) forty (40) ornamental grasses, groundcover, or perennials at a minimum of one (1) gallon in size, (v) sod at minimum to the rear corner of the residence are required at each street yard.

100'+ wide lots – The following are landscape requirements for lots, which are classified as one hundred foot (100') or larger lots: (i) minimum of three (3) four inch (4'') trees or four (4) three-inch (3'') trees (ii) two (2) ornamental trees with a minimum of two-inch (2'') caliper, (iii) forty (40) shrubs at a minimum of five (5) gallon in size, (iv) forty (40) ornamental grasses, groundcover, or perennials at a minimum of one (1) gallon in size, (v) sod at minimum

8.1 Landscape Design

to the rear corner of the residence are required at each street yard.

On corner lots an additional six- (6) shrubs per fifty-foot (50') of residence wall are required in the street-facing yard, at the house and in front of the fence perpendicular to the house side elevation, if applicable; and in addition to any side yard fence screening requirements.

See the Approved Plant List for suggested plant material, and plants which are prohibited from use.

Refer to specific Neighborhood Design Guidelines and Supplemental Conditions for additional landscape requirements.

The street yard is defined as the yard, which is adjacent to any street. If there is a greenbelt that separates the street from the street yard, then a variance request must be submitted to the AC if the *owner/builder* wishes to eliminate any of the required installed trees or landscaping. The elimination of these trees is totally at the discretion of the AC, and previous variances for similar situations will not be considered. Credit is provided for these tree requirements for existing 3" caliper or larger canopy trees, which remain in each street yard, providing each, are in healthy condition. Credit is given on a 2:1 ratio. For example, there are two (2) 3" trees existing in the yard, this will allow the *owner/builder* to request a variance to eliminate one of the required trees to be installed.

Credit must be approved by the AC and submitted on the Variance Request form that can be found in the Appendix. (see Submittal Requirements, Section 3.1). Trees are measured at 6" above the grade of the ground at installation. Existing trees which have a 19-1/2 inch caliper or greater which have been removed or destroyed, must be replaced with a combination of trees (minimum diameter 4") that are equal or greater in caliper than the tree that was removed/destroyed. Caliper is measured six (6) inches above finish grade.

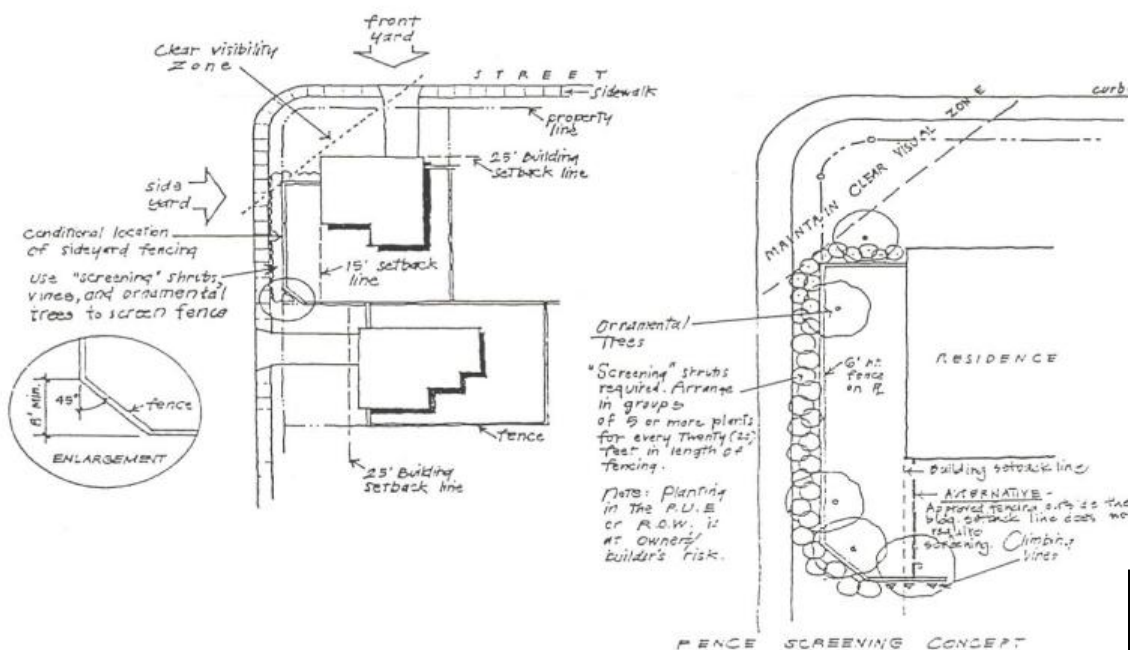

8.1 Landscape Design

“**Screening**” shrubs are defined as shrubs contained in 5-gallon containers minimum, selected from the Approved Plant List, which reach a 5-ft. height minimum at maturity. At the time of installation, “screening” shrubs must be large enough to immediately screen the item, containing dense evergreen or semi-evergreen foliage to provide year around screening.

Large Shrubs are defined as shrubs contained in 5-gallon containers which will reach a mature height of 4 ft. or larger.

Small shrubs are defined as 1 or 2 gallon container plants, which reach a mature height of less than 4 ft.

To maintain sight line corridors, shrub heights within the street R.O.W. must not exceed thirty (30) inches in height at maturity.

Gravel is discouraged as ground cover. However, if gravel is to be used for ground cover, it must be submitted to the AC for approval and at least 50% of the area must remain plant material. Gravel in areas that are visible from the street must be submitted to the committee for review. Dry creek beds may be permitted, but will need to be

submitted to the AC for approval.

Imitation or plastic plants, including synthetic turf materials, are prohibited.

Proposed planting plan schemes for *units* visible from the street which do not contain any turf areas must be approved. The use of railroad ties for landscape or decorative use is prohibited.

Use of “Screening” Shrubs

To be considered for approval as a variance, fences within a side street setback must be screened using “screening” shrubs (See Section 7.5, Fences & Freestanding Walls). “Screening” shrubs must relate to the street in a coherent pattern, (i.e., arranged in sweeping groups of five (5) or more plants for every twenty (20) feet in length of fencing. Shrubs must be maintained clear of the street sidewalk, street and intersection visibility zone. Shrub spacing shall be 30 inches on center (30” o.c.) or less to ensure adequate screen cover. In all cases, screening must be complete and without void.

If an *owner/builder* chooses to use plant material as a means to screen utility meters and air conditioning condensers, in lieu of

fencing, the following requirements must be followed:

- Evergreen shrubs, which are 18”-24” at installation (5-gallon) and reach 4’-5’ height at maturity, must be used to screen utility boxes that are within twenty (20) feet of the curb. Approved plant material would be elaeagnus, viburnum, lorapetalum, or cotoneaster. Any other plant material must be approved in advance by the AC.
- Screening must not block the door/access of an electric transformer. Shrubs can not be planted any closer than 10’ to door side, to allow access by utility company.
- AC units should be screened with screening shrubs, as defined above, or with fencing. Having the AC unit behind the backyard privacy fence would be preferable.

Using “screening” plants for the purpose of screening landscape elements as described above are **in addition** to the minimum number of required front yard plants (See previous page).

Guidelines:

8.1 Landscape Design

Emphasis should be given to trees, shrubs and ground covers that provide seasonal interest and color. Use low growing shrubs, ground covers, and limited quantities of annuals to enhance the front of the *residence*, especially the entry area. For example, plant material can help define outdoor spaces

by providing enclosure, or framing a view. Plant material that provides wildlife habitat is encouraged, trees and shrubs bearing nuts and berries, for example.

Minimize large areas of turf and emphasize ground cover plantings to minimize water use.

If a *unit* is completed between 1 October and 30 April, a temporary turf of annual rye or fescue should be established in order to prevent soil erosion before a permanent turf is planted in the Spring (see Approved Plant List for suggested types).

8.2 Installation & Maintenance

Goals:

Healthy, attractive, and thriving landscapes.

With a little care in the plant installation and initial maintenance program of landscaped areas, the homeowner should enjoy his or her landscape environment for many years to come with minimal upkeep.

Requirements:

Owners must maintain all *improvements* within their *residence* except the *improvements* described in the Declaration that are being maintained by the *Association*.

Each *owner* must maintain all landscaping within the City/County right-of-way (ROW) located on his *unit* between the pavement of the street and his *residence*.

Owners/builders are prohibited from making additional *improvements* within or upon any areas that are being maintained by the *Association*, or from performing additional maintenance (such as, but not limited to tree trimming) of any existing *improvements* that are being maintained by the *Association* without consent and approval of the

Association as applicable, that is maintaining such *improvements* or the area in which such *improvements* are located.

All *improvements* upon a *unit* must be maintained in good condition and repair and in a clean and attractive condition. Any slopes and terraces must be maintained so as to prevent any erosion upon adjacent streets or adjoining property.

Shrub and ground cover beds must be edged to keep out grasses and weeds.

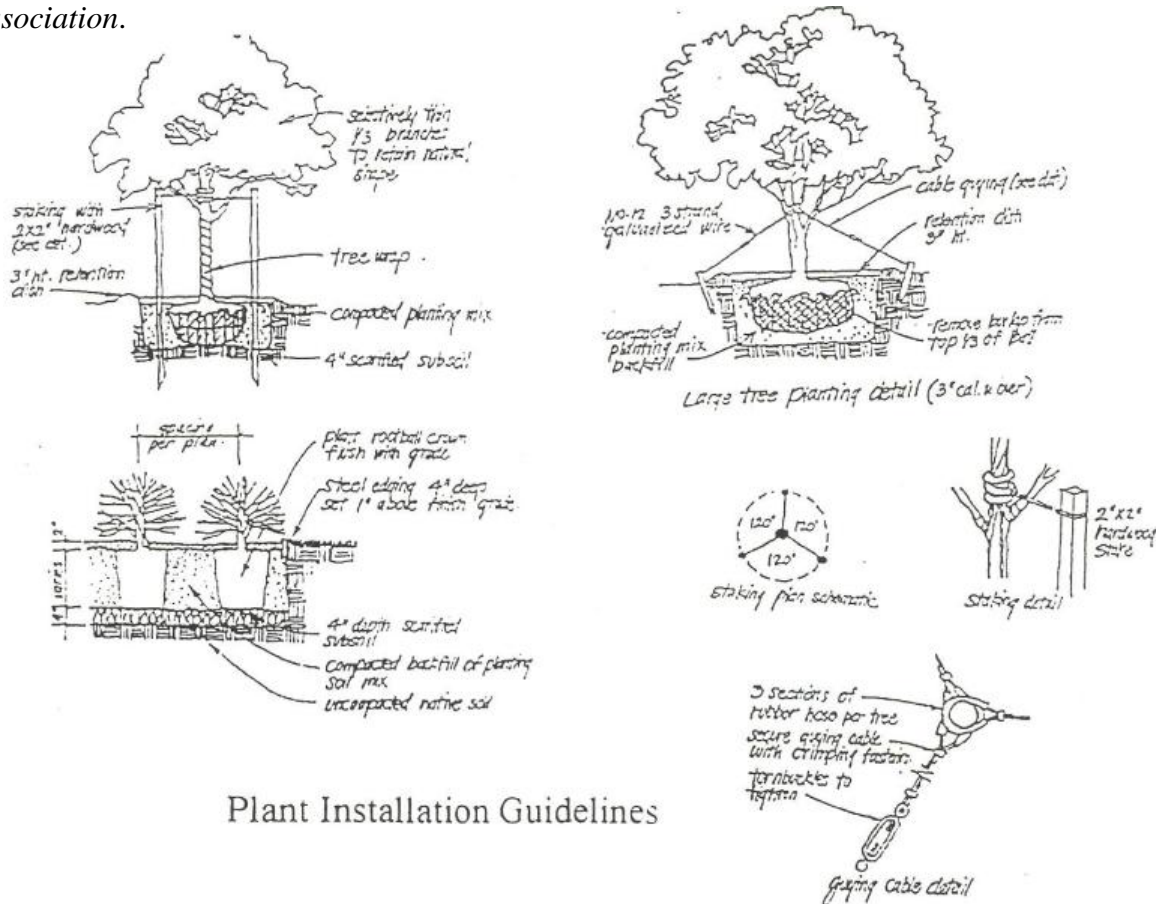

Plant Installation Guidelines

8.2 Installation & Maintenance

Sufficient water must be applied to maintain plants in a healthy condition the year round, subject to water restrictions, which may be imposed by WCID#17 or any future water supplier.

Turf must be kept mowed and edged the year round in accordance with community-wide standards.

Guidelines:

Trees and shrubs should be planted in accordance with normal horticultural practices. Suggested planting details are shown on the previous page. The City of Austin Environmental Manual is also a source for plant installation recommendations. Tree installation is best performed in the fall and winter months to ensure survivability.

Containerized trees should be planted between 15 March and 15 October. Balled and burlap wrapped trees can also be installed at this time as well as during the remainder of the year.

Periodically check guy wires and stakes on newly planted trees to ensure the tree is well supported. Protect the tree trunk from guy wire damage with rubber hoses. Remove guy wires and stakes one to two growing seasons after the tree roots have become established.

Black plastic edging is discouraged.

Landscape irrigation should occur before 10 a.m. or after 7 p.m. and in conjunction with governmental jurisdictional recommendations or guidelines to avoid excessive evaporation.

Landscape areas installed with an automatic irrigation system should be scheduled to water, at most, every five (5) days between 10 p.m. and 5 a.m. when water demand is lowest.

Less water is used if the grass lawn is used as an indicator: when grass does not spring back after being walked on, it is time to water.

All tree species are susceptible to deer browsing. Small caliper tree plantings should not be left unprotected. Trees should be caged with mesh wire until the canopy is taller than deer can reach.

Immediately paint all wounds, including fresh pruning cuts, on Live Oaks and Red Oaks to minimize the possible spread of oak wilt disease. If possible, pruning should be avoided during the period from 1 February to 1 June. A coat of tree-wound paint acts as a

barrier, which stops fungal spores carried by insects, from entering the wound. Painting old wounds is not beneficial.

8.3 Integrated Pest Management

Goals:

The goal of Integrated Pest Management (IPM) on Steiner Ranch is to reduce non-point source pollution and protect the Edwards Aquifer.

Many pesticides used in the lawn and garden have been found to be harmful to people, pets and the environment. By using a program of IPM, an ecological approach to pest management in the lawn and garden, the homeowner can minimize the use of harmful chemicals and contribute to a better environmental quality.

General:

Information and strategies regarding IPM are constantly being improved and updated. To the greatest extent possible, the most recent information will be included in this Manual. Additional sources include the City of Austin Environmental and Conservation Services Department and Texas Natural Resources Conservation Commission. IPM is an approach to pest control that employs a progression of physical, mechanical, biological, and

chemical tactics to keep pest problems low enough to prevent intolerable damage or annoyance.

The use of persistent chemical products should be avoided if at all possible. This is a primary emphasis of the IPM plan. Regularly scheduled pesticide application is not IPM. The following guidelines outline a general IPM approach to lawn care. More specific information on lawn care, common lawn pests and common household pests is included in the appendix. Other IPM concerns beyond the scope of this Manual include the following:

- 1) Proper disposal and methods of recycling of nickel/cadmium batteries.
- 2) Proper disposal or recycling of motor oil
- 3) Proper vehicle maintenance techniques.

Steiner Ranch residents and *owner/builders* should abide by established City and State guidelines. Additional information is available from the sources listed above.

Guidelines:

Plan the landscape carefully by choosing species of grasses, groundcovers, shrubs, and trees, which are pest-resistant and appropriate for the particular site conditions (see Approved Plant List). Whenever possible, include species of grasses, groundcovers, shrubs, and trees which also provide forage and/or cover for birds. For example, in the spring, 65% of a robin's diet may consist of insect grubs. Before installing plant material, have the soil tested and add suggested amendments for the most vigorous plant growth. Increase organic content by adding compost to soil.

Maintain plant health by providing adequate moisture through irrigation and mulching. Keep dead material pruned away and fertilize when recommended.

Make use of preparations from your local nursery, which introduce disease into the pest insect population. Once such product is Bacillus Thuringiensis, which is a fungus that controls webworms.

8.3 Integrated Pest Management

If pests become a problem, take the following steps:

Physical Control: Change the habitat of pests by adding mulch or by moving/adding plants (some plants are naturally pest repellent). Capture pests by hand or in traps and remove from the site.

Biological Control: Encourage pests' natural predators and parasites. Avoid using chemical insecticides, which could destroy the "good" insects, such as ladybugs, spiders, and braconid wasps, along with the "bad". These beneficial insects can also be purchased from local nurseries.

The Last Resort: If these controls are not effective, some pesticides can be used relatively safely in the lawn and garden. Rotenone, for example, is a product of biological origin that controls many types of insects. Dormant oil is another such product that controls pests on fruit trees.

There are also some synthetic organic insecticides, which have a low toxicity level, such as Malathion, which controls many common pests. However, for most effectiveness and safest usage, consult with your local nursery expert.

Pesticides Prohibited under the Steiner Ranch Conservation Easement – Balcones Canyonlands Preserve

-  Atrazine/Gesprim 50
-  Azinphos-methyl
-  Bendiocarb/Ficam
-  Carbaryl/Sevin
-  Chlorinated hydrocarbon pesticides
-  Chlorpyrifos/Dursban
-  Lindane
-  Malathion/Cythion
-  Methyl parathion
-  Pentachlorophenol/Permite
-  Propoxur/Baygon

** This list is effective as of 10/1/00, and is in effect until such time as it is updated.

8.4 Plant List

The following list of plants is composed of selected native and adaptive plant material suitable for the plant habitat found on Steiner Ranch. This Approved Plant List is made up of recommended plants for installation on the property. Plants not listed on the approved plant list are not necessarily prohibited. Please see the prohibited plant list for a comprehensive list of plants currently not allowed for installation in Steiner Ranch.

Non-invasive plants are recommended for all homes in Steiner Ranch, regardless of whether they are adjacent to the preserve or open space/greenbelts.

As regional and xeriscape gardening techniques become more mainstream, thereby increasing demand, additional plant species will become available in the marketplace. Therefore, this list of recommended plants will be amended from time to time.

It should be emphasized that plants suitable for one locale of Steiner Ranch may not be so for all areas. For example, plants installed on a west facing upland slope are not necessarily suitable for a protected valley setting containing a heavy tree cover.

Due to the sometimes-harsh planting conditions, knowledge in plant identification and growth characteristics is strongly recommended for planting design.

Oak wilt is a problem for live oaks and red oaks, including Spanish Oak and Blackjack Oak, throughout Central Texas. Oak wilt is a fungal disease that clogs the water conducting vessels of infected trees, causing the tree to wilt and die. Improper pruning and not sealing freshly cut wounds is known to be a predominant cause for the spread of oak wilt.

There is no known cure. At this time, the disease has not become established on the property. Other Oak species, noted on the approved list below, are not susceptible to this disease.

For oak wilt information, contact the Texas Forest Service – Oak Wilt Project (451-2178), Travis County Extension service (473-9600) and the City of Austin Oak Wilt Suppression Project (476-6487).

8.4 Plant List

NOTE: THE FOLLOWING PLANTS/SHRUBS/TREES ARE PROHIBITED:

| <u>Scientific Name:</u> | <u>Common Name:</u> | <u>Reason prohibited:</u> |
|---------------------------|-----------------------------------|---|
| Photonia glabra | Red Tip Photinia | Intolerant of deer, especially in immature plants |
| Nerium Oleander | Oleander | Extremely poisonous to wildlife and domestic animals |
| Melia azedarach | Chinaberry | Non-native invasive plant which will choke out native plants necessary for native wildlife and endangered species |
| Nandina Domesitca | Nandina | See reason for Chinaberry |
| Ligustrum (All varieties) | Ligustrum | Highly invasive. See Chinaberry |
| Lonicera japonica | Japanese Honeysuckle | See reason for Chinaberry |
| Vitex agnus-castus | Lilac Chaste Tree | See reason for Chinaberry |
| Vinca Minor | Creeping Myrtle, Periwinkle | See reason for Chinaberry |
| Vinca Major | Big Leaf Periwinkle | See reason for Chinaberry |
| Sapium sebiferum | Chinese Tallow | See reason for Chinaberry |
| Sorghum halipense | Johnson Grass | See reason for Chinaberry |
| Tamarix | Salt Cedar/ Tamarisk | See reason for Chinaberry |
| Andropopon ischaemum L. | King Ranch Bluestem | See reason for Chinaberry |
| Ricinus communis | Castor Bean | See reason for Chinaberry |
| Ailanthus altissima | Tree of Heaven | See reason for Chinaberry |
| Pistacia chinensis | Chinese Pistache | See reason for Chinaberry |
| Populus deltoids | Eastern Cottonwood | Short-lived and disease prone |
| Crytomium falcatum | Holly Fern Non-clumping Bamboo | See reason for Chinaberry Highly invasive. See Chinaberry |

Canopy Trees:

| <u>Scientific Name:</u> | <u>Common Name:</u> | <u>Comments:</u> |
|--------------------------------|---------------------|------------------|
| Acer grandidentatum | Bigtooth Maple | fall color |
| Carya illinoensis | Pecan | tree litter |
| Fraxinus texensis | Texas Ash | |
| Juglans microcarpa | Texas Black Walnut | |
| Pistacia texensis | Texas Pistache | |
| Platanus occidentalis glabrata | Sycamore | moist areas |
| Magnolia Grandiflora | Magnolia | drought tolerant |
| Quercus muhlenbergii | Burr Oak | |
| Quercus glaucoides | Lacey Oak | |

8.4 Plant List

| | | |
|----------------------------|-------------------|------------------|
| Quercus pungens ‘Vaseyana’ | Chinquapin Oak | |
| Quercus shumardii | Shumard Oak | fall color |
| Quercus sinuata | Shin Oak | drought tolerant |
| Sapindus drummondii | Western Soapberry | drought tolerant |
| Taxodium distichum | Bald Cypress | moist |
| Ulmus americana | American Elm | |
| Ulmus crassifolia | Cedar Elm | drought tolerant |
| Ulmus parvifolia | Chinese Elm | |
| Ulmus parvifolia ‘Drake’ | Drake Elm | fast growing |

Ornamental Trees:

| <u>Scientific Name:</u> | <u>Common Name:</u> | <u>Comments:</u> |
|--------------------------|-------------------------|-------------------------|
| Acacia wrightii | Wright Acacia | full sun |
| Aesculus arguta | Texas Buckeye | DR |
| Aesculus pavia | Red Buckeye | |
| Bumelia lanuginosa | Wooly-Bucket Bumelia | sun/drought |
| Cercis canadensis alba | Whitebud | |
| Cercis canadensis texana | Texas Redbud | sun/drought |
| Chilopsis linearis | Desert Willow | DR |
| Cornus drummondii | Rough Leaf Dogwood | shade/DR |
| Crataegus reverchonii | Reverehon Hawthorn | |
| Crataegus tracyi | Mountain Hawthorn | fall color |
| Diospyros texana | Texas Persimmon | sun/drought/DR |
| Ilex decidua | Possumhaw Holly | sun/shade |
| Ilex vomitoria | Yaupon Holly | sun/drought |
| Juniperus ashei | Cedar | sun/drought |
| Koelreuteria paniculata | Goldenrain Tree | susceptible to freeze |
| Lagerstroemia indica | Crape Myrtle | sun/summer color |
| Parkinsonia aculeata | Jerusalem Thorn | sun |
| Pinus eldarica | Afgan Pine | |
| Prunus americana | American Plum | |
| Prunus caroliniana | Carolina Laurel Cherry | moist soils, subject to |
| Prunus mexicana | Mexican Plum | Chorosis |
| Prunus serotina ‘eximia’ | Escarpment Black Cherry | |

Ornamental Trees cont.:

| <u>Scientific Name:</u> | <u>Common Name:</u> | <u>Comments:</u> |
|-----------------------------|-------------------------|----------------------|
| Pyrus calleryana ‘Bradford’ | Bradford Pear | white flower, formal |
| Rhamnus caroliniana | Carolina Buckthorn | moist soils |
| Rhus lanceolata | Prairie Flameleaf Sumac | sun/drought/DR |
| Rhus glabra | Smooth Sumac | sun/drought/DR |
| Sophora secundiflora | Texas Mountain Laurel | sun/drought/DR |
| Ungnadia speciosa | Mexican Buckeye | sun/DR |

8.4 Plant List

Shrubs:

| <u>Scientific Name:</u> | <u>Common Name:</u> | <u>Comments:</u> |
|-------------------------------|---------------------|------------------|
| Abelia grandiflora | Glossy Abelia | |
| Agave americana | Agave/Century Plant | full sun/drought |
| Anisacanthus wrightii | Flame Acanthus | tolerant |
| Callicarpa americana | French Mulberry | sun/DR |
| Cephalanthus occidentalis | Button Bush | sun/shade/moist |
| Cotoneaster horizontalis | Cotoneaster | moist areas |
| Dasyliirion texanum | Texas Sotol | sun |
| Escallonia | Escallonia spp. | sun/DR |
| Eupatorium havanense | Shrubby Boneset | sun |
| Eysenhardtia texana | Texas Kidneywood | moist |
| Forestiera pubescens | Texas Elbow Bush | sun/drought |
| Fouquieria splendens | Ocotillo | |
| Garrya ovata | Silk Tassel | sun |
| Hesperaloe parviflora | Red Yucca | |
| Ilex vomitoria | Yaupon Holly | sun/DR |
| Ilex vomitoria 'Nana' | Dwarf Yaupon | sun/shade |
| Lantana horrida | Texas Lantana | DR |
| Leucophyllum frutescens | Texas Sage | sun/DR |
| Lindera benzoin | Spice-bush | sun/drought/DR |
| Mahonia trifoliolata | Agarita | shade/moist |
| Mahonia swaseyi | Texas Mahonia | sun/drought/DR |
| Myrica cerifera | Wax Myrtle | shade |
| Pistacia texana | Texas Pistache | sun/shade |
| Prunus rivularis | Creek Plum | |
| Prunus reverchonii | Reverchon Hog Plum | moist |
| Rhus aromatica | Fragrant Sumac | sun |
| Rhus virens | Evergreen Sumac | DR |
| Rosmarinus officinalis | Rosemary | drought/DR |
| Sabal texana | Texas Sabal Palm | drought/DR |
| Sophora affinis | Eve's Necklace | DR |
| Symphoricarpos Orbiculatus | Coralberry | sun/shade |
| Viburnum rufidulum | Rusty Blackhaw | |
| Yucca pallida | Viburnum | sun/drought |
| | Pale Leaf Yucca | DR |

Groundcovers:

| <u>Scientific Name:</u> | <u>Common Name:</u> | <u>Comments:</u> |
|---------------------------|---------------------|-------------------|
| Achillea millefolium | Yarrow | full sun/shade/DR |
| Adiantum capillus-veneris | Maidenhair Fern | moist areas/shade |
| Ajuga reptans | Ajuga | shade/DR |
| Aquilegia canadensis | Columbine | shade |
| Dryopteris spp. | Wood Fern | shade/moist/DR |

8.4 Plant List

| | | |
|-------------------------------------|--------------------|----------------------|
| Hedera helix | English Ivy | shade |
| Juniperus conferta 'Blue Pacific' | Shore Juniper | sun/DR |
| Liriope muscari | Liriope | sun/shade |
| Lonicera sempervirens | Coral Honeysuckle | sun/shade |
| Mahonia repens | Creeping Mahonia | shade |
| Nolina texana | Beargrass | sun/DR |
| Ophiopogon japonicus | Monkey Grass | shade/DR |
| Pavonia lasiopetala | Pavonia | sun |
| Phlox drummondii | Drummond's phlox | sun |
| Phlox subulata | Thrift | sun |
| Poliomentha longiflora | Mexican Oregano | sun/DR |
| Rosmarinus officinalis 'prostratus' | Trailing Rosemary | sun/DR |
| Salvia farinacea | Mealy Sage | sun/DR |
| Salvia greggii | Cherry Sage | sun/DR |
| Salvia romeriana | Cedar Sage | sun/DR |
| Santolina chamaecyparissus | Gray Santolina | sun/drought |
| Santolina virens | Green Santolina | sun/drought tolerant |
| Tradescantia spp. | Spiderwort | shade |
| Verbena bipinnatifida | Prairie Verbena | sun/DR |
| Verbena elegans 'asperata' | Hardy Verbena | sun/DR |
| Yucca rupicola | Twisted-leaf Yucca | sun/drought/DR |

Grasses:

Scientific Name:

Andropogon gerardii
 Andropogon scoparius
 Bouteloua curtipendula
 Bouteloua gracillis
 Buchloe dactyloides
 Cynodon spp.
 Festuca glauca
 Festuca Spp. 'Arid'
 Hilaria belangeria
 Leptochloa dubia
 Miscanthus sinensis 'zebrinus'
 Muhlenbergia lindheimeri
 Panicum virgatum
 Sorghastrum nutans
 Stenotaphrum secundatum
 Tripsacum dactyloides
 Zoysia spp.

Common Name:

Big Bluestem
 Little Bluestem
 Sideoats Gramma
 Blue Gramma
 Buffalo Grass
 Bermuda Grass
 Blue Fescue
 Tall Fescue
 Common Curly mesquite
 Green Sprangletop
 Zebra Grass
 Big Muhly
 Switchgrass
 Indiangrass
 St. Augustine Grass
 Eastern Gamagrass
 Zoysia Grass

Comments:

tall seed heads

 drought tolerant

 drought tolerant

 ornamental
 drought
 shade/drought

 clump

 moist

Vines:

Scientific Name:

Common Name:

Comments:

8.4 Plant List

| | | |
|-----------------------------|-------------------------|------------|
| Bignonia capreolata | Crossvine | evergreen |
| Campsis radicans | Trumpet Creeper | aggressive |
| Clematis pitcheri | Leather Flower | delicate |
| Gelsemium sempervirens | Carolina Yellow Jasmine | |
| Ipomoea Quamoclit | Cypress Vine | annual |
| Lonicera sepmervirens | Coral Honeysuckle | |
| Mauranda antirrhinniflora | Snapdragon Vine | delicate |
| Parthenocissus quinquefolia | Virginia Creeper | shade |

Annuals:

Winter/Spring:

Calendula
 Daffodil (bulb)
 Hyacinth (bulb)
 Ornamental Kale
 Pansy
 Poppy
 Primula
 Snapdragon
 Tulip (bulb)
 Ornamental Pepper
 Dianthus

Spring/Summer:

Geranium
 Marigold
 Periwinkle
 Petunia

Summer/Fall:

Acalypha
 Ageratum
 Alyssum
 Amaranthus

Summer/Fall cont.:

Begonia
 Caladium
 Chrysanthemum
 Coleus
 Impatiens
 Marigold
 Periwinkle
 Phlox
 Portulaca
 Purslane

Legend For Approved Plant List:

| | |
|------------------------------------|---|
| Full sun/sun | sun-loving plant |
| Shade | shade-loving plant |
| Moist | moist loving plant |
| Drought/drought tolerant | plants generally able to survive on less supplemental water and better able to withstand droughts |
| Fall color | fall leaf color |
| DR | deer resistant plants unpalatable enough to be left alone as long as other food is available |
| Ornamental | showy plant |

9. Sign Guidelines

Goals:

Providing clear sign information in an un-obtrusive manner while reinforcing the overall Steiner Ranch theme.

Controlling the location and type of sign within Steiner Ranch maintains aesthetic standards that should benefit all Steiner Ranch residents.

Requirements:

No sign may be displayed within the property without the prior written approval of the *Architectural Committee*. However, the *Declarant/Developer* has the right to install marketing signs at their discretion within the community, which, in their opinion, may enhance the image and marketability of property within Steiner Ranch.

Refer to specific Neighborhood Design Guidelines and Supplemental Conditions for additional sign requirements.

The *Architectural Committee* must approve, in writing, all signs prior to installation.

Sign Criteria:

All signs must be maintained in a neat and orderly fashion. Correction of any deficiencies must be made immediately and by the entity responsible for the maintenance of said sign.

Color: Earth tones may be used. Any other colors must be submitted to the AC for approval.

Material: Wood, corrugated plastic, and aluminum, non-glare, non-reflective. No hand painted or spray painted signs may be used.

Developer Signs:

The developer will create and maintain a master marketing sign program to direct traffic to subdivision sections and model homes.

Builder Signs:

The following signs are allowed for use by the builders:

- One (1) for sale sign per lot limited to a maximum size of 2' x 3' at a height not to exceed 4' above the ground. The "for sale" sign must be located in front of the front building setback, and may not be located in any portion of the lot adjacent to a golf course lot.

- One (1) 4'x8' sign, not to exceed ten feet (10') in

height overall, to designate the construction trailer for each builder in a subdivision section

- Model home monument and marketing signs not to exceed 4'x6' for the sign face. Maximum of two (2) flagpoles and two (2) flags are allowed to be installed with the monument sign. Size, materials, and location of monument sign and flagpoles/flags must be submitted to the AC for review and approval before installation.

All builder signs, with the exception of "for sale/sold" signs, must be submitted to the AC for approval of materials, colors, and locations.

"Bandit" signs are not permitted within the property or along the frontage of Ranch Road 620. "Bandit" signs are defined as any unapproved, temporary, directional signs, not installed on the unit.

Realtor "For Sale"/Marketing Signs:

The following signs are allowed for use by realtors acting as agents for Steiner Ranch homeowners or homeowners acting as their own agents:

- One (1) for sale sign per lot, located on the lot for sale, limited to a maximum size of 2' x 3' at a height

9. Sign Guidelines

not to exceed 4' above the ground. The "for sale" sign must be located in front of the front building setback, and may not be located in any portion of the lot adjacent to a golf course lot. Signs are not allowed to be mounted on windows, inside or outside.

- "Open House" signs are allowed with the same specifications as the "For Sale" signs, but are limited to being displayed for a period two (2) hours before the open house and to be removed within two (2) hours following the open house

If all sign conditions/restrictions are met, no further approval is necessary for installation of the signs.

"Bandit" signs are not permitted within the property or along the frontage of Ranch Road 620.

In the event a residence or lot for sale is located on a joint use driveway, an additional directional sign will be allowed at one entrance to the joint use driveway. This sign must be a generic directional sign that says either "For Sale" or "Open House". In all cases, no more than one generic "for sale" and one generic "open house" sign may be located at the

entrance to a joint use driveway, regardless of how many residences or lots are for sale on the joint use driveway.

Homeowner Signs:



The following signs are allowed for use by homeowners:

- Temporary signs for 24 hours or less, such as "Garage Sale", "Birthday", or "Anniversary". These signs must be no more than 2' x 3', and must not exceed 4' in height.
- Temporary signs for "New Baby" may be erected for seven (7) days





Prohibited Signs:

No sign or billboard is permitted to be displayed on any portion of Steiner Ranch except as required by law, City of Austin, and Travis County ordinance and these Regulations in connection with the sale, lease or exchange of such property.

Other Prohibited Signs:

-  Attachment of notices to street signs, light poles, or any unauthorized locations within Steiner Ranch is prohibited.
-  Signs, which obstruct the clear view of pedestrian or vehicular traffic, or interfere with

efficient operations of vehicles.

-  Off-premise signs (signs not located on the *unit*), including signs or graphics applied to parked vehicles for nearby vendor identification. The only exception is the one "for sale" and one "open house" sign allowed at the entry to a joint use driveway.
-  Signs or graphics painted directly on exterior of buildings or displayed in windows.
-  Landscaping that becomes a message or a sign.
-  Graphics painted on or adhered to trash bins (with the exception of the trash company logo) or their enclosures.
-  Signs not in compliance with other governmental agencies.

Condominium projects, attached or detached, require additional requirements and guidelines. The following requirements and guidelines are intended as a supplement to the overall Residential Design Guidelines Manual. All Residential Design Guidelines Manual restrictions and guidelines still apply to condominium units, unless otherwise stated in the following Condominium Requirements & Guidelines.

10. Condominium Requirements & Guidelines

Submittal Requirements

The following requirements must be met for a submittal to be accepted for review. The submittal must be made to the AC prior to being submitted to any other governing body, in order to prevent unnecessary re-submittals to these governing bodies.

The construction or installation of any Improvements, changes to existing Improvements, expansion, demolition, or the reconstruction of Improvements, will require the submission of plans and specifications for the AC review and approval before any such construction or installation activity is commenced. The AC may waive plan and specification requirements for certain Improvements at its discretion. There are seven (7) standard submittals as follows:

- ❖ Conceptual Site Plan/ Site Development
- ❖ Final Site Plan/ Site Development
- ❖ Preliminary Building Construction Plans
- ❖ Final Building Construction Plans
- ❖ Preliminary Landscape Plans
- ❖ Final Landscape Plans

❖ Site or Building Modification Plans

An applicant making any of these submittals should carefully review this manual before making a submittal.

The individual submittal requirements are reviewed in later sections; however there are some general guidelines to follow for each submittal.

- ❖ Plans and specifications for construction of any Improvement within Steiner Ranch must be submitted to the AC for approval.
- ❖ All architectural and engineering plans must be prepared by registered professionals licensed to practice in the State of Texas.
- ❖ Any revisions to the plans and/or specifications must be resubmitted as an addendum to the original application.
- ❖ Completed plans, specifications and applications must be submitted to Steiner Ranch Master Association, Inc., Attn: AC, 12550 Country Trails Lane, Austin, Texas 78732.

Preliminary Submittal Program Review

In an effort to expedite the submittal process, the owner/applicant is encouraged to meet with an AC representative at an early stage for a pre-submittal program review. Although not mandatory, the review is intended to address any submittal uncertainties before much time and effort has been spent.

Time and effort will be saved with an understanding of submittal requirements. The AC's representative is available to answer questions.

Conceptual Site Plan/ Site Development Submittal

After meeting with the AC on the preliminary design, the next step would be to submit the Site Plan Application. The following are items, which should be submitted to the committee for review:

- ❖ Two (2) copies of the appropriate completed and executed submittal application form
- ❖ Two (2) copies of the conceptual site/land use plan, at a legible scale, preferably 1"=50'-0", with the following preliminarily proposed information clearly indicated:
 - Lot layout with dimensions and



10. Condominium Requirements & Guidelines

- orientation of all residences
- Building setbacks and dimensions to all property lines
- Building setbacks and dimensions between properties and to the private street or joint-use driveway. If a typical or minimum dimension is to be used to define the spacing between residences, then the typical or minimum measurement should be clearly defined on all pages of the site plan.
- Estimated building size for each typical residence (square footage)
- A statistical summary of building areas, number of required parking spaces, and percentage of lot usage
- Site entrances (ingress and egress), driveways, parking, estimated areas of cut and fill, entry walks and sidewalks with locations and widths, dimensions and parking setbacks
- Street or public right-of-way sidewalks, if required, showing locations and widths
- Location and type of proposed walls and fencing (specifications to be submitted with Preliminary Construction Plans)
- Utility layout and service locations
- Landscape locations, including location and size of trees greater than 8" in diameter
- Location of construction trailers, storage units, construction access and parking, portable toilet and dumpster locations, material stockpile areas, debris stockpile areas and construction fencing
- legible scale, preferably 1"=20'-0", approved by the AC.
- Site topography and finish grade contouring including all cut and fill areas
- Existing topographical lines.
- Slab elevation, existing and finish grade at corners of each residence, driveway, and corners of *unit* or lot. If a typical or minimum dimension is to be used to define the finish elevation, then the typical or minimum measurement should be clearly defined on all pages of the site plan.
- Lot layout with dimensions and orientation
- Building location on the lot indicating building setbacks and dimensions to all property lines
- Building footprint with building dimensions and area (square footage)
- Percentage of site covered by building footprint(s); percent of site

Final Site Plan/ Site Development Submittal

- ❖ Final Site Plans should include, but are not limited to all Preliminary Site Plan documents and the information indicated above, including any additional requirements imposed by the AC
- ❖ Two (2) copies of the appropriate completed and executed submittal application form
- ❖ Two (2) copies of the Final Site Plan at a



10. Condominium Requirements & Guidelines

- covered by impervious cover
- Grading and drainage plan of entire site, including internal drainage provided for in the parking areas.
- Site entries, driveways, parking (residence and guest spaces), sidewalks with dimensions and parking setbacks
- Street or public right-of-way sidewalks, if required
- Locations, types and preliminary designs of retaining walls, free-standing walls and fencing
- Utility layout and service locations
- Locations of loading and service areas
- ❖ Any other information or documentation deemed necessary by the AC
- ❖ Please note, if the architectural plans for residences are not submitted at the time of the site plan review, then the overall plan layout is still subject to review and change once the building dimensions are finally determined.

Site clearing may not begin, until the final site plan submittal is approved.

Preliminary Building Construction Plan Submittal

Preliminary Construction Plans should incorporate additional information and elaborate on preliminary information provided on the Conceptual Site Plan.

This submittal should include the following “Preliminary Construction” level plans and information:

- ❖ Two (2) copies of the appropriate completed and executed submittal application form
- ❖ 2 copies of building plans at minimum scale of 1/8"=1'-0" including:
 - Floor plan with proposed finished slab, finished floor elevations and building square footage
 - Exterior elevations, including dimensions to highest point of each building
 - Roof plan
- ❖ Plans for foundation screening, per requirements in section 6.2.
- ❖ 2 copies of preliminary Product Specifications/Description of

Materials for building structures, landscape, sign and lighting. Specifications should include exterior color and material descriptions and should be accompanied by product samples

- ❖ Any other information or documentation deemed necessary by the AC

Final Building Construction Plan Submittal

- ❖ Final Plans should include, but not be limited to all Preliminary Construction documents and the information indicated above, including any additional requirements imposed by the AC
- ❖ Any other information or documentation deemed necessary by the AC

Construction may not begin, until the final construction plan submittal is approved.

10. Condominium Requirements & Guidelines

Preliminary Landscape Plan Submittal

- ❖ Two (2) copies of the appropriate completed and executed submittal application form
- ❖ 2 copies of landscape plans at minimum scale of 1"=40'-0".
- ❖ Locations, types and preliminary designs of site sign
- ❖ Locations, types and preliminary designs of site lighting
- ❖ Locations and types of all fencing or walls
- ❖ Locations, types and sizes of any existing trees on the site 8" or greater in diameter
- ❖ Landscape and irrigation layouts for site, buildings and public right-of-way areas

Final Landscape Plan Submittal

- ❖ Final Landscape Plans should include, but not be limited to all Preliminary Landscape documents and the information indicated above, including any additional requirements imposed by the AC
- ❖ Any other information or documentation deemed necessary by the AC

Construction may not begin, until the final construction plan submittal is approved.

Modification Submittals

Approval for any modifications or alterations to an existing structure must be submitted for approval to the AC. The submission requirements are as follows:

- ❖ Two (2) copies of the architectural modification application, completed and executed
- ❖ A scaled drawing showing the plan and elevation views of proposed improvements, modifications or alterations.
- ❖ Samples depicting the proposed materials and colors to be used

Note: If the condominium residence is part of a Maintenance Association, the Maintenance Association must first review your plans to evaluate if the proposed improvements are within your legal property rights. Plans will not be considered submitted to the SRMA Architectural Committee until the Maintenance Association's legal review has taken place, and they have signed the submittal application stating the improvements are within the legal rights of the property. It is the builder/owner's

responsibility to ensure that plans have been properly processed through their Maintenance Association. Any application which is not within property rights of the applicant cannot be reviewed by the SRMA Architectural Committee.

10. Condominium Requirements & Guidelines

Approval Process:

Approval of any plans and specifications shall be valid for a period of one (1) year from the date of the approval from the AC. If construction has not commenced within one (1) year after the AC has issued its final approval, the *owner/builder* will be required to resubmit the plans and specifications to the AC, and the AC shall have the authority to charge and additional review fee for review of the resubmitted item, and may consider any change in circumstances, which may have occurred since the initial approval. The AC will have the authority to stipulate a period for completion of any *Improvements* at that time.

Completion of initial construction is required within twenty-four (24) months from date of site plan approval, unless an extension is submitted and approved by the AC.

Construction Inspection:

Form Survey – The *owner/builder* must submit a form survey prior to pouring concrete. The purpose of this survey is to verify that site grading and foundation locations have

been prepared according to the approved submittal and the regulations.

If the *owner/builder* pours a foundation without receiving a written form survey approval, the *owner/builder* may be responsible for removing and replacing the foundation in accordance with the approved submittal.

Final (As-built) Survey – A final survey of the location of the residences must be submitted before a final inspection can be scheduled.

Final Inspection – Upon completion of all residence *improvements*, and within seven (7) days of any closings or occupancies, the *owner/builder* must notify the AC the construction is complete and the *improvement* is ready for a final inspection. If any of the residences close without an inspection, a fine will be assessed (see fine/fee list). If the property fails to pass the initial inspection, there will be a re-inspection fee for each additional inspection. If *owner/builder* desires to have a phased inspection to allow for several residences to be inspected at one time, a schedule

must be submitted to and approved by the AC.

Note: Please refer to specific Neighborhood Design Guidelines and Supplemental Conditions for specific requirements and guidelines regarding setbacks or façade requirements.

Building Setbacks

Condominium projects, attached and detached, do not have individual property lines between units or buildings, therefore setbacks are not measured as on standard single family residential lots. Please see the following guidelines to determine interior setbacks of residences.

Front setback – Ten feet (10') minimum from front of residence to internal street or private drive, with at least twenty feet (20') of driveway to the unit to allow for two parked cars.

Side setback – Ten feet (10') minimum between residences.

Rear setback – Twenty feet (20') minimum from rear of one residence to the side of another residence.



10. Condominium Requirements & Guidelines

Thirty feet (30') from the rear of one residence to the rear of any other residence or other properties. In all cases, the residences must be set back from all adjacent property lines a minimum of twenty-five feet (25').

The AC, in its sole discretion, will make the decision of which setback requirement must be met in situations where the setback is difficult to determine.

Façade Design

Façade design for condominium projects is established by the Development Area Declaration for that section. In all cases, the same residence plan or building configuration (in the case of attached condominiums) must be separated by at least one other residence or building configuration (in the case of attached condominiums), including the residence or building directly across the private street or drive. If the condominium project chooses to do a similar exterior color theme and materials, it must be submitted to and approved by the AC.

No more than two of the same plan, elevation, or color may be located in a

four-house block. The four-house block is defined as the subject house, each house to the side, and the house directly across the street.

Driveways and Parking

The *unit* driveways must be no less than fifteen feet (15') wide and must maintain at least five feet (5') of separation from other *unit* driveways.

The private driveway or joint-use driveway for the condominium project must meet requirements of Travis County ESD#6 for emergency access parking and turnaround. The paved private drive shall be no less than twenty-four feet (24') in width. Parking is prohibited on the private drive.

Parking spaces for condominium projects must allow for adequate parking for each residence as follows:

- For residences with one (1) to two (2) bedrooms (as determined by the AC), one (1) garage and one (1) driveway parking space is required
- For residences with three (3) or more bedrooms (as determined by the AC), two (2)

garage and two (2) driveway parking spaces are required

- Additional guest spaces, separate from the residence, at a ratio of one (1) space for every four (4) residences are required. The guest spaces should be evenly distributed and reasonably accessible from intended residences, and be located off the joint-use driveway or private street.
- All parking must meet ADA requirements.
- No more than six (6) guest spaces shall be clustered together in one parking area.

Sidewalks

All sidewalks must meet ADA requirements and should be a minimum of four feet (4') wide. The sidewalks located within any R.O.W. on the condominium unit should meander through the property, but should be at least four to six feet (4' – 6') from any property line.

Screening

Areas that require screening include, but are not limited to transformers, utility pedestals, lift stations, meters, air



10. Condominium Requirements & Guidelines

conditioning units, back flow preventers, pool equipment, driveways over 3' in height, and garbage can storage areas. Please see Section 7.4 Screening for details on screening these items.

Utility meters must be located on side or rear elevations of the residences.

Public dumpsters for condominium projects must have an approved enclosure with additional landscape.

Fences, Gates & Walls

Please see section 7.5 Fences, Gates & Walls for restrictions and guidelines regarding fences, gates and walls.

Fence heights must be at a minimum of five foot (5') in height. Wrought iron fence is allowed without further approval.

If fences are required by the Development Area Declaration for the site, the fence must be installed before construction may begin, unless further approval is granted by the AC to delay installation.

Accessory Structures

Note: If the condominium residence is part of a Maintenance Association, the Maintenance Association must first review your plans to evaluate if the proposed improvements are within your legal property rights. Plans will not be considered submitted to the SRMA Architectural Committee until the Maintenance Association's legal review has taken place, and they have signed the submittal application stating the improvements are within the legal rights of the property. It is the builder/owner's responsibility to ensure that plans have been properly processed through their Maintenance Association. Any application which is not within property rights of the applicant cannot be reviewed by the SRMA Architectural Committee.

Please see Section 7.7 Accessory Structures for requirements and guidelines for Accessory Structures.

Wood Decks

Note: If the condominium residence is part of a Maintenance Association, the

Maintenance Association must first review your plans to evaluate if the proposed improvements are within your legal property rights. Plans will not be considered submitted to the SRMA Architectural Committee until the Maintenance Association's legal review has taken place, and they have signed the submittal application stating the improvements are within the legal rights of the property. It is the builder/owner's responsibility to ensure that plans have been properly processed through their Maintenance Association. Any application which is not within property rights of the applicant cannot be reviewed by the SRMA Architectural Committee.

Please see Section 7.8 Wood Decks for requirements and guidelines for Wood Decks.

Wood decks or patios, if approved by the committee, may not extend past the side walls of the residence.

Landscape Requirements

Landscape for open areas:

10. Condominium Requirements & Guidelines

Landscape plans in open areas must be submitted to the AC for review, but at minimum should include landscaping at the guest parking of one (1) tree per four (4) spaces and ten (10) five-gallon plants. Additional landscaping may be required by the AC at entries, property lines adjacent to properties owned by others, or to screen unsightly equipment or structures as determined by the AC.

Landscape for individual residence, for each yard (front, sides, and/or rear) facing a street or private drive, is determined by the overall width of the residence as follows:

- Up to 39' in width: (i) minimum of two (2) three-inch (3") trees, (ii) twenty (20) shrubs at a minimum of five (5) gallon in size, (iii) twenty (20) ornamental grasses, groundcover, or perennials at a minimum of one (1) gallon in size, and (iv) sod at minimum to the rear corner of the residence are required at each street yard.
- 40 – 49' in width: (i) minimum of two (2) three-inch (3") trees, (ii) twenty (20) shrubs at a minimum of five (5) gallon in size, (iii) twenty (20) ornamental grasses, groundcover, or perennials at a minimum of one (1) gallon in size, and (iv) sod at minimum to the rear corner of the residence are required at each street yard.
- 50' – 59' width: (i) minimum of two (2) three-inch (3") trees (ii) twenty-five (25) shrubs at a minimum of five (5) gallon in size, (iii) twenty-five (25) ornamental grasses, groundcover, or perennials at a minimum of one (1) gallon in size, (iv) sod at minimum to the rear corner of the residence are required at each street yard.
- 60' – 69' width: (i) minimum of two (2) four inch (4") trees or three (3) three inch (3") trees (ii) thirty (30) shrubs at a minimum of five (5) gallon in size, (iii) thirty (30) ornamental grasses, groundcover, or perennials at a minimum of one (1) gallon in size, (iv) sod at minimum to the rear corner of the residence are required at each street yard.
- 70' – 79' width: (i) minimum of two (2) four inch (4") trees or three (3) three inch (3") trees (ii) one (1) ornamental tree with a minimum of two-inch (2") caliper, (iii) thirty-five (35) shrubs at a minimum of five (5) gallon in size, (iv) thirty-five (35) ornamental grasses, groundcover, or perennials at a minimum of one (1) gallon in size, (v) sod at minimum to the rear corner of the residence are required at each street yard.
- 80' – 89' width: (i) minimum of two (2) four inch (4") trees or three (3) three inch (3") trees (ii) one (1) ornamental tree with a minimum of two-inch (2") caliper, (iii) forty (40) shrubs at a minimum of five (5) gallon in size, (iv) forty (40) ornamental grasses, groundcover, or perennials at a minimum of one (1) gallon in size, (v) sod at minimum to the rear corner of the residence are required at each street yard.
- 90' and larger in width: (i) minimum of three (3) four inch (4") trees or four (4) three-inch (3") trees (ii) two (2) ornamental trees with a minimum of two-inch (2") caliper, (iii) forty (40) shrubs at a minimum of five (5) gallon in size, (iv) forty (40) ornamental grasses, groundcover, or perennials at a minimum of one (1) gallon in size, (v) sod at minimum to the rear corner of the residence are required at each street yard.

(40) ornamental
grasses, groundcover,
or perennials at a
minimum of one (1)
gallon in size, (v) sod
at minimum to the rear
corner of the residence
are required at each
street yard.

Tree credits may be
granted as noted in Single-
Family Residential
guidelines and will be
determined at the sole
discretion of the AC.

10. Wildland Urban Interface (WUI) Guidelines

Background:



The Steiner Ranch development is located in an “urban wildland interface”, which is a geographical area where homes meet the forest. A home in a woodland setting is surrounded by flammable forest fuels, which can be a real danger if a wildfire is on the loose.

These guidelines are intended to provide fire-protection recommendations to owners of lots within the Steiner Ranch development. The Master AC has adopted these guidelines as a public service to the Lot owners of Steiner Ranch.

Disclaimer: Neither the MASTER AC, the STEINER RANCH MASTER ASSOCIATION, INC., nor TAYLOR WOODROW COMMUNITIES/ STEINER RANCH, LTD., a Texas limited partnership, is a guarantor of fire safety within the Steiner Ranch development. Each owner and resident is solely responsible for the security of their property in the event of fire and assumes all risks for loss or damage to same.



Requirements:

Vegetation

-  Areas within 10 feet on each side of roadways and driveways should be cleared of non fire-resistive vegetation growth; provided, however, single specimens of trees, ornamental vegetative fuels, or cultivated ground cover, such as green grass, ivy, succulents, or similar plants used as ground cover may be located within 10 feet of roadways and driveways, provided they do not form a means of readily transmitting fire.
-  No vegetation should be planted under or adjacent to energized power lines that, at maturity, are expected to grow within 10 feet of the energized conductors.
-  All plants will burn under extreme fire weather conditions such as drought. However, plants burn at different intensities and rates of consumption. Fire-resistive plants burn at a relatively low intensity, slow rates of spread, and with short flame lengths. Fire-resistive vegetation is

encouraged within Steiner Ranch.

Ignition Source Control

-  Except with respect to the use of approved equipment in inhabited premises, equipment and devices generating heat, sparks or open flames capable of igniting nearby combustibles may not be used within Steiner Ranch without a permit from the Master AC.
-  Fireworks may not be used or possessed within Steiner Ranch.
-  Building, igniting, or maintaining an outdoor fire of any kind for any purpose within Steiner Ranch is prohibited; provided, however, that outdoor fires within inhabited premises or designated areas where such fires are in a permanent barbecues, portable barbecue, outdoor fireplace/ fire pit, or grill and are a minimum of 30 feet from any combustible material or non fire-resistive vegetation are permitted. Permanent barbecue, portable barbecues, outdoor fireplaces, or grills may not be used for the disposal of rubbish, trash, or combustible waste material.





10. Wildland Urban Interface (WUI) Guidelines

 Incinerators, outdoor fireplaces, permanent barbecues, and grills may not be built, installed, or maintained within Steiner Ranch without the advance consent of the Master AC. Incinerators, outdoor fireplaces, permanent barbecues, and grills must be maintained in good repair and in a safe condition at all times. Openings in such appliances should be provided with an approved spark arrestor, screen or door.

 The Master AC is authorized to stop any actions of a person or persons if the Master AC determines that the action is reckless and could result in an ignition of fire or spread of fire.

Control of Storage

 Hazardous materials in excess of 10 gallons of liquid, 200 cubic feet of gas, or 10 pounds of solids require a permit from the Master AC and must comply with nationally recognized standards for storage and use.

 Explosives may not be possessed, kept, stored, sold, offered for sale, given away, used, discharged,

transported, or disposed of within Steiner Ranch, except by permit from the Master AC.

 Outside storage of combustible materials such as, but not limited to, wood, rubber tires, building materials or paper products is prohibited without the advance consent of the Master AC.

Dumping

 Waste material may not be placed, deposited, or dumped within Steiner Ranch, or in, on, or along trails, roadways, or highways or against structures.

 Ashes and coals should not be placed, deposited, or dumped within Steiner Ranch; provided, however, ashes and coals may be deposited: (i) in the hearth of an established fireplace; or (ii) in a noncombustible container with a tight-fitting lid, which is kept or maintained in a safe location not less than 10 feet from non fire-resistive vegetation or structures.

Recommendations:
10 Simple Steps to Protect Your Home from Wildland Fire. Wildfire can strike if you have not taken some

steps to protect your house and property. The actions and precautions listed below are designed to help you prepare your home and lessen the threat of wildland fire damage to you and your property

 LPG tanks should be far enough away from buildings for valves to be shut off in case of fire. Keep area around the tank clear of flammable vegetation.

 Store gasoline in an approved safety can away from occupied buildings.

 All combustibles such as firewood, wooden picnic tables, boats, stacked lumber, etc. should be kept away from structures.



 Clear roof surfaces and gutters regularly to avoid build-up of flammable materials such as leaves and other debris.

 Remove branches from trees to a height of 15 feet or more.

 Clear a fuel break of at least 3 times the fuel length around all structures.

 Have fire tools handy such as: ladder long enough to reach your roof, shovel, rake, and a bucket or two for water.

10. Wildland Urban Interface (WUI) Guidelines

-  Place connected garden hoses at all sides of your home for emergency use.
-  Assure that you and your family know all emergency exits from your home.
-  Assure that you and your family know all emergency exits from your neighborhood.

Fire Safe in the Interface

 **Defend your space in the interface.** Make a fire-safe zone around your home. Remove flammable vegetation and leaves at least 30 feet from the house.

 **Don't add fuel to the fire; break the "chain".** Examine your house and yard. What can catch fire or carry it to your home? Evergreens catch fire easily and burn quickly. Prune lower limbs, thin out the trees to remove them from the safety zone. Leave yard trees and shrubs no closer than 15-20 feet apart. Remove limbs overhanging the roof and chimneys. Clean gutters and roof of leaves and needles. Store firewood 30-100

feet away from the house. Use fire-resistant roofing materials.

 **Be home-safe in the interface.** Make sure firefighters can find your home. Mark your house location clearly.













If you are interested in learning more about Wildland Urban Interface, and what you can do, please visit these sites:

<http://txforestservicetamu.edu>

<http://ims.spaceimaging.com/swra>

<http://www.tamu.edu/ticc/UWI.htm>

11. Appendix

-  “Fine/Fee List”
-  “Master Plan Submittal Application Form”
-  “Master Plan Submittal Exterior Masonry Calculations”
-  “Plot Plan Submittal Application Form”
-  “Masonry Guidelines/ Color Selection Form”
-  “Architectural Modification Application/Approval Form”
-  “Pool Addendum”
-  “Deck Addendum”
-  “Greenbelt Addendum”
-  “Construction Inspection Report – New Construction”
-  “Construction Inspection Report – Modifications”
-  Reference article – “Controlling Common Household Pests Safely”
-  Selected City of Austin Construction Standards:
 - ◆ Sidewalk
 - ◆ Curb ramp, type 1 & 2
 - ◆ Driveway

Please contact HOA office for most up to date forms.

Fine/Fee List

Note: All fines/fees apply to new construction and modifications, unless otherwise noted.

All fines due 30 days after receipt, unless otherwise specified when assessed. Fees will be due as specified below.

| | |
|---|---------|
| Construction deposit per lot (\$5000 maximum per builder & subdivision) | \$500* |
| Beginning Construction without Approval | \$500 |
| Pouring foundation w/o approved form survey | \$250 |
| Variance request for encroachments w/o notice | \$100 * |
| Inspection not scheduled | \$250 |
| Final Inspection | \$50 |
| Re-inspections: | |
| 2 nd Inspection | \$250 |
| 3 rd Inspection | \$500 |
| 4 th Inspection (and any subsequent inspections) | \$1000 |
| Deposit for Architectural Modifications (check will be deposited, if inspection not called in) | \$500 |
| Deposit for accessing greenbelt (check will be deposited) | \$500 |
| Disturbance of greenbelt w/ no deposit held (also liable for damages +50%) Per citation (maximum 2 citations)*** | \$500 |
| AC Violations (per citation)***) | \$250 |
| Failing to meet completion date on modifications (per week) | \$50 |

In the event, the “Declarant” is required to repair, clean up or provide necessary service to bring the improvement into compliance, the owner/builder will be assessed the cost of repair, clean up, or service plus an additional 50% for time and service expended. This will include, but is not limited to repair of common area landscaping, providing a dumpster or chemical portable toilet, adding inlet protections or silt fencing.

* Construction deposit must be posted before any application is made for plot plan approval in that subdivision. Construction may not begin until this deposit is received. The deposit will be returned when all houses in the subdivision pass final inspection and all associated fines have been paid.

** Variance requests for encroachments into setbacks should be made to the AC to allow for processing time. If request is made less than seven days before the house is to close, a fine will be instituted as stated above.

*** Citation is defined as notification of violation, and a time frame to have violation rectified. If violation is not rectified during the required time frame, HOA will make repairs and bill the violator for the repairs plus and additional 50% for time and service expended.



**STEINER RANCH MASTER ASSOCIATION (SRMA)
ARCHITECTURAL COMMITTEE
MASTER PLAN SUBMITTAL APPLICATION FORM**

Date Submitted: _____

Phase(s): _____ Section #(s): _____ Section Name(s): _____

Builder/Applicant Name: _____

Builder/Applicant Address: _____

Builder/Applicant Phone No.: _____ Fax No: _____

REQUEST FOR APPROVAL OF:

- MASTER PLAN(S)** (2 copies must be submitted – all elevations w/options, roof plan, site plan - **ONLY**)
Plan Series Name (if applicable): _____ (One plan series per page)
- PRODUCT SPECIFICATIONS/DESCRIPTION OF MATERIALS SUBMITTED**
- OPTIONS – PLAN SPECIFIC** (must include square footage for each option)

| <u>PLAN NO./NAME</u> | <u>ELEVATIONS</u> | <u>B/B/L/D/S</u> | <u>MASONRY %</u> | <u>SO.FT.LIVING</u> | <u>BASE PRICE</u> | <u>OPTIONS</u> |
|----------------------|-------------------|------------------|------------------|---------------------|-------------------|----------------|
| 1) _____ | _____ | _____ | _____ | _____ | _____ | _____ |
| 2) _____ | _____ | _____ | _____ | _____ | _____ | _____ |
| 3) _____ | _____ | _____ | _____ | _____ | _____ | _____ |
| 4) _____ | _____ | _____ | _____ | _____ | _____ | _____ |
| 5) _____ | _____ | _____ | _____ | _____ | _____ | _____ |
| 6) _____ | _____ | _____ | _____ | _____ | _____ | _____ |

I _____ (Applicant), certify to the best of my knowledge that the above answers are correct and truthful and understand that the above are not all inclusive conditions and restrictions concerning the Steiner Ranch community.

Applicant Signature: _____

Note: Plans and specifications submitted for review are **not** being reviewed for structural integrity; compliance with zoning and building ordinances or any other applicable statutes, ordinances or governmental rules or regulations, compliance with the requirements of any public utility, easement or other agreements, or preservation of any view.

| FOR OFFICE USE ONLY | | <u>YES</u> | <u>NO</u> |
|--|---------|--------------------------|--------------------------|
| DEED RESTRICTIONS: | | | |
| Single Family? | | <input type="checkbox"/> | <input type="checkbox"/> |
| Minimum/Maximum Square Footage Requirement? | | <input type="checkbox"/> | <input type="checkbox"/> |
| Garage? | | <input type="checkbox"/> | <input type="checkbox"/> |
| Masonry Requirements: | | | |
| Minimum Percentage (%) of Total Exterior Masonry Area Required | _____ % | <input type="checkbox"/> | <input type="checkbox"/> |
| Roofing - Non-reflective? | | <input type="checkbox"/> | <input type="checkbox"/> |
| Insurance certificate received? | | <input type="checkbox"/> | <input type="checkbox"/> |
| Construction Deposit received? | | <input type="checkbox"/> | <input type="checkbox"/> |

Application is: Approved Not Approved Date: _____

Comments: _____

COMMITTEE:

J. Robert Long James D. Plasek Scott Selman

Builder AC Representative Builder AC Representative



**STEINER RANCH MASTER ASSOCIATION
ARCHITECTURAL COMMITTEE
MASTER PLAN SUBMITTAL - EXTERIOR MASONRY CALCULATIONS**

Date Submitted: _____

Builder/Applicant: _____

MASONRY CALCULATIONS:

| Plan No: (Note: For all Plan Descriptions, Refer to Pg. 1) | | | | | | | | | | | |
|---|--|----------|----------|----------|----------|----------|----------|----------|----------|----------|-----------|
| | Calculation Item | 1 | 2 | 3 | 4 | 5 | 6 | 7 | 8 | 9 | 10 |
| A. | Total Exterior Wall Surface (SF) | | | | | | | | | | |
| B. | Deduct Gables, Windows, Door Openings (SF) | | | | | | | | | | |
| C. | Total Net Exterior Wall Surface (SF) | | | | | | | | | | |
| D. | Total Exterior Masonry Area (SF) | | | | | | | | | | |
| E. | *Total Exterior Masonry Percentage (%) (Total Ext. Masonry/Total Net Ext. Wall Surface) | | | | | | | | | | |

Note: Item E (Total Exterior Masonry Percentage) Must Meet Minimum Masonry Requirements as Outlined in the Applicable Covenants, Conditions and Restrictions (CC & R's) for Steiner Ranch



Steiner
Ranch

STEINER RANCH MASTER ASSOCIATION (SRMA)
ARCHITECTURAL COMMITTEE
SUBMITTAL APPLICATION FORM
PLOT PLAN AND MASONRY SELECTION

REQUEST FOR APPROVAL OF:

Plot Plan (Complete)

Masonry Select/Hold

Plot Plan Only

Masonry Re-Select

Property Address: _____ Date Submitted: _____

Subdivision Name: _____ Phase: _____ Section: _____ Block: _____ Lot: _____ Lot Size: _____

Plan Series: _____ Plan Number: _____ Elevation Number: _____

Owner Name or Spec?: _____ Builder/Contact: _____

Phone No.: _____ Phone No.: _____

Fax No: _____ Fax No: _____

PROJECTED START OF CONSTRUCTION: _____

ATTACHED OR REFERRED TO WITH THIS SUBMITTAL ARE:

- 1 Plot Plan for subject lot.
- Elevation showing masonry accents (if applicable)
- Construction Compliance Agreement
- Construction Deposit

APPLICANT TO COMPLETE THE FOLLOWING, INDICATING THAT THE FOLLOWING MINIMUM DEED COVENANTS HAVE BEEN MET:

DEED RESTRICTIONS:

ACTUAL CONDITION

YES NO

Single Family?

Dwelling Size/Living Area (To outside face of framing) _____ sq.ft.

Additional Approved Options added: _____ sq.ft.

Floor Plan/Elevation Dissimilar to Adjacent Properties?

Garage: Attached Detached Side Entry Number of Cars: _____ Orientation: RF LF

Masonry Requirements:

Color/Manufacturer: _____

Mortar Color: _____

Percent (%) of Stone: _____ Brick: _____ Stucco: _____ Siding: _____

Stucco/Siding Color: _____

Trim Color: _____

Roofing – Non-reflective? _____ Color: _____

Sidewalks per subdivision plat? Required Front Required Side

Landscaping to be installed per Design/Supplemental Guidelines?

I _____ (Applicant), certify to the best of my knowledge that the above answers are correct and truthful and understand that the above are not all inclusive conditions and restrictions concerning the Steiner Ranch community. I have read the relevant development area declarations. Applicant Signature: _____

Note: Plans and specifications submitted for review are **not** being reviewed for structural integrity; compliance with zoning and building ordinances or any other applicable statutes, ordinances or governmental rules or regulations, compliance with the requirements of any public utility, easement or other agreements, or preservation of any view.

For Office Use Only

AC Deposit received Compliance Agreement received Application is: Approved Not Approved

Date: _____

Comments: _____

AC Coordinator

Steiner Ranch Master Association, Inc.
ARCHITECTURAL COMMITTEE
CONSTRUCTION COMPLIANCE AGREEMENT

This agreement is made by and between the Steiner Ranch Master Association, Inc. (the "Association") and _____, who is the Owner (or who is acting on behalf of the Owner) of real property located within the Steiner Ranch Master Association, Inc. Master Planned Community (the "development") of Austin, Texas, known as Lot ____, Block ____, within the unit of the development known as _____, and which is more commonly known by its street address, which is _____. Owner acknowledges the Association is not limited to enforce only the following stipulations but has the right and duty to uphold and enforce all rules, restrictions and guidelines of the Steiner Ranch Master Association, Inc.

- (a) Owner or Owners Representative has this day deposited with the Association the sum of Five Hundred Dollars (\$500.00) for the above-referenced property, representing the Owners agreement to fully and faithfully construct improvements on Owners property in compliance with all applicable deed restrictions, design guidelines and supplemental guidelines, and rules and regulations of the Association and the Architectural Committee (the "AC").
- (b) Prior to any construction or lot clearing Owner agrees to install permanent perimeter fencing on all sides of Owner lots that border Association Common Area, greenbelts, land preserve or any other property owner in the above referenced development. If permanent perimeter fencing is a metal picket fence Owner is required to install orange construction fencing against the metal fence to help control trash and other debris from adjacent property(ies). Additional orange construction and silt fence requirements are stipulated in the Declaration, Design & Supplemental Guidelines.
- (c) Owner agrees to ensure that only the materials needed to construct a dwelling on a given lot will be delivered to and stored upon said lot. At no time will materials be allowed to be delivered or stored upon Association Common Area, greenbelts, Golf Course property, land preserve or any other property other than the lot where the materials will be utilized.
- (d) If, at any time prior to the completion of construction of Owners improvements or landscaping, Owner or Owners contractors or subcontractors fail to repair any damage to the common areas within ten (10) days after the Association serves on Owner written demand to make the repair, then the Association shall appropriate and apply any portion of the construction deposit as may be reasonably necessary to make the repairs plus 50%, as well as assess the charges outlined in the attached schedule.

- (e) If, at any time prior to the completion of construction of Owners improvements or landscaping, Owner or Owners contractors or subcontractors fail to construct improvements or install landscaping in accordance with approved plans, within ten (10) days after the Association serves on owner written demand to correct the non-compliance, the Association shall appropriate and apply any portion of the construction deposit as may be reasonably necessary to bring the property into compliance, as well as assess the charges outlined in the attached schedule.
- (f) All charges against the compliance fee will be at the sole discretion of the Association. The Owner is required to pay all charges against the compliance fee within ten (10) days of written notification of charges by the Association. Any Owner wishing to appeal the assessment of a violation charge defined above may do so by submitting a written request of the appeal to the Association stating the reasons of the appeal and requesting to appear before the AC at a regularly scheduled meeting.
- (g) In the event the compliance fee charges exceed the five hundred dollar (\$500.00) deposit, Owner will be required to pay all additional charges assessed by the Association within ten (10) days of notice of charges plus Five-Hundred Dollars (\$500.00) to meet the required compliance fee deposit.
- (h) The Association will hold the compliance fee until the following items have been met: 1) all home construction by builder in subject section is complete, 2) all final inspections are passed, 3) all inspection fees/builder fines have been paid in full, 4) all greenbelt, common area, street/sidewalks have been inspected and any required repairs are complete, 5) in private roadway sections submittal of compliance with ADA by certified inspector must be submitted. If there is actual cause for retaining all or any portion of the compliance fee, the Association will supply Owner with a written description and itemized list of all deductions. Such deductions will be limited to damages and charges for which you are legally liable under this agreement or as a result of a breach of this agreement.

This Agreement is executed and accepted on this the ____ day of _____, 20__.

OWNER/OWNERS REPRESENTATIVE:

 Printed Name: _____
 Mailing Address: _____

Date: _____

STATE OF TEXAS §

COUNTY OF TRAVIS §

BEFORE ME, a Notary Public, on this day personally appeared _____, known to me to be the person whose name is subscribed to the foregoing instrument, and acknowledged to me that he executed the same for the purposes and consideration therein expressed.

GIVEN UNDER MY HAND AND SEAL OF OFFICE, this the ____ day of _____, 20____.

NOTARY PUBLIC, State of Texas

STEINER RANCH MASTER ASSOCIATION, INC.,
a Texas non-profit corporation

By: _____ Date: _____
Printed Name: _____
Its _____

STATE OF TEXAS §

COUNTY OF TRAVIS §

BEFORE ME, a Notary Public, on this day personally appeared _____ of the Steiner Ranch Master Association, Inc. a Texas non-profit corporation, known to me to be the person whose name is subscribed to the foregoing instrument, and acknowledged to me that he executed the same for the purposes and consideration therein expressed, in the capacity therein stated, and on behalf of said corporation.

GIVEN UNDER MY HAND AND SEAL OF OFFICE, this the ____ day of _____, 20____.

NOTARY PUBLIC, State of Texas

SCHEDULE

\$500 COMPLIANCE FEE-New Construction

Compliance Fees are payable in conjunction with final plan submittal. Payment of fees does not grant a variance for the violation. All violations must be corrected to come into compliance. If there is a subsequent violation of the same rule, the fee will double with each subsequent violation.

Violation Charges:

| | |
|--|---------------------------|
| CONSTRUCTION COMMENCEMENT WITHOUT APPROVAL BUILDING PERMIT (Construction is defined as <i>any</i> site work, with the exception of "stringing") | \$500* |
| POURING FOUNDATION WITHOUT APPROVED FORM SURVEY | \$250 |
| CONSTRUCTION NOT IN ACCORDANCE WITH APPROVED PLANS (Significant changes in design/Changes in Materials) | \$300* Each Occurrence |
| VARIANCE REQUEST FOR ENCROACHMENTS WITHOUT NOTICE/ APPROVAL | \$100 |
| FINAL INSPECTION NOT SCHEDULED | \$250 |
| FINAL INSPECTION FEE | \$ 50 |
| RE-INSPECTIONS: | |
| 2 ND INSPECTION | \$250 |
| 3 RD INSPECTION | \$500 |
| 4 TH INSPECTION | \$1000 |
| DAMAGE TO COMMON AREA/GREENBELT (Also liable for damages +50%) | \$100* Each Occurrence |
| SITE NOT PROPERLY MAINTAINED (72 hours notice to correct violation will be given prior to assessing charge) | \$ 50/day |

Construction Dumpster (or alternative approved by the ACC) and
Portable Toilet not on-site prior to commencement of construction
Trash and Debris (Defined as any materials that are capable of blowing into
other properties)
Construction materials stored on other property without written permission
from such Owner
Construction fencing not used at side and rear property lines

***These violations may also be subject to a fee of \$50/day until the violation is corrected.**



Steiner
Ranch

STEINER RANCH MASTER ASSOCIATION (SRMA) &
RESIDENTIAL OWNERS ASSOCIATION (SRROA)
ARCHITECTURAL COMMITTEES
MASTER PLAN APPLICATION

Date Submitted: _____

Phase(s): _____ Section #(s): _____ Section Name(s): _____

Builder/Applicant Name: _____

Builder/Applicant Address: _____

Builder/Applicant Phone No.: _____

Builder/Applicant Fax No.: _____ Builder/Applicant Email: _____

REQUEST FOR APPROVAL OF:

- Two MASTER PLAN(S)** (All elevations, roof plan, site plan)
Plan Series Name (if applicable): _____
- PRODUCT SPECIFICATIONS/DESCRIPTION OF MATERIALS SUBMITTED**
- OPTIONS – PLAN SPECIFIC** (must include square footage for each option)

PLAN NO. PLAN NAME ELEVATIONS B/B/L/D/S MASONRY % SQ.FT.LIVINGBASE PRICE
OPTIONS

I _____ (Applicant), certify to the best of my knowledge that the above answers are correct and truthful and understand that the above are not all inclusive conditions and restrictions concerning the Steiner Ranch community. I have read the Development area deed restrictions and this plan has been designed per the restrictions.

Applicant Signature: _____

Note: Plans and specifications submitted for review are **not** being reviewed for structural integrity; compliance with zoning and building ordinances or any other applicable statutes, ordinances or governmental rules or regulations, compliance with the requirements of any public utility, easement or other agreements, or preservation of any view.

FOR OFFICE USE ONLY

DEED RESTRICTIONS:

| | YES | NO |
|--|--------------------------|--------------------------|
| Single Family? | <input type="checkbox"/> | <input type="checkbox"/> |
| Minimum/Maximum Square Footage Requirement? | <input type="checkbox"/> | <input type="checkbox"/> |
| Garage? | <input type="checkbox"/> | <input type="checkbox"/> |
| Masonry Requirements: | | |
| Minimum Percentage (%) of Total Exterior Masonry Area Required _____ % | <input type="checkbox"/> | <input type="checkbox"/> |
| Roofing - Non-reflective? | <input type="checkbox"/> | <input type="checkbox"/> |
| Insurance certificate received? | <input type="checkbox"/> | <input type="checkbox"/> |
| Compliance Agreement & Deposit received? | <input type="checkbox"/> | <input type="checkbox"/> |

Application is: Approved Not Approved Date: _____

Comments: _____

COMMITTEE:

J. Robert Long
AC Chairman

James D. Plasek
AC Representative

Scott Selman
AC Representative

Builder AC Representative

Builder AC Representative



**STEINER RANCH MASTER ASSOCIATION (SRMA)
ARCHITECTURAL COMMITTEE
CUSTOM MASTER PLAN SUBMITTAL APPLICATION FORM**

Applicant Name: _____ Date: _____

Property: _____

Mailing Address (If Different from Property): _____

Applicant Contact Phone Number(s): _____

Applicant E-mail Address: _____

Contractor Name (If Applicable): _____

Contractor Phone Number (If Applicable): _____

Please list the modifications to the dwelling and/or addition of accessory structure(s) for which you are requesting approval:

The following items must accompany this request:

- Plan with elevation views of proposed improvements at a minimum of 1/8 inch scale. Provide a description of materials to be used (including dimensions & color samples).
- Plot plan indicating location of proposed improvements and dimensions to adjacent property lines (the dimensions should be clearly marked in feet and inches)
- Any addendum specific to the modification. (Ex: pool, deck, etc.)

The AC may request that you provide additional information before a decision on your request can be determined. The application is not complete until all information requested has been received. All modifications must comply with applicable deed restrictions and design guidelines. A \$500.00 refundable deposit check must be submitted before the application will be reviewed. The AC has a maximum of thirty (30) days to render a decision. Any work commencing prior to receiving written approval is a violation and will constitute fines. Call (512) 266-7553 if you have any questions.

Please read the following statements and initial next to each line to indicate that you have read and understand the statement:

1. ___ I have read the guidelines and agree to abide with them in regards to the modification as proposed.
2. ___ I understand that I must submit a \$500.00 refundable deposit before my application will be reviewed.
3. ___ I understand that any contractors I employ are **not** permitted to place signs on my property advertising their business.
4. ___ I understand that greenbelt access is **not** granted for construction without written permission from the Architectural Committee. (A formal application and a second deposit must be submitted before a greenbelt access request will be considered by the Architectural Committee.)
5. ___ I hereby agree not to begin any improvements or changes until the Architectural Committee notifies me of their approval in writing.
6. ___ I understand that **any** changes to the approved plans must be resubmitted to the Architectural Committee **before** the changes are implemented.
7. ___ I understand that I must call to schedule an inspection no more than seven (7) days after the assigned completion date. Deadline extension requests must be submitted in writing. ****Please note that it is the responsibility of the homeowner, not the contractor, to call in the inspection.****

Owner Name (Print)

Signature of Owner

FOR OFFICE USE ONLY

Architectural Modification Application is: Approved Not

Approved

Date Reviewed: _____ Date Improvements to be Completed: _____

Comments: _____

Architectural Control Committee:



**STEINER RANCH MASTER ASSOCIATION (SRMA) AND STEINER
RANCH RESIDENTIAL OWNERS ASSOCIATION (SRROA)
ARCHITECTURAL COMMITTEES**

POOL ADDENDUM (submit with Modification Application)

| |
|---|
| <p align="center"><u>Pre-Gunite Inspection</u></p> <p>Cal lin: _____</p> <p>Re-inspect: _____</p> <p>Passed: _____</p> <p>Inspector: _____</p> |
|---|

Applicant Name: _____ **Date Submitted:** _____

Property Address: _____

Applicant Contact Phone Number & e-mail: _____

Contractor Name: _____

Contractor Phone Number & e-mail: _____

The following items are required for pool and/or spa construction and must be shown on the survey/site plan/pool plan: **(Please initial all items)**

_____ Location of pool in relation to house. Please note all existing easements and setbacks. Show all dimensions to pool from rear and side property lines. Note: Form survey required if pool or deck is within one foot of any setback.

_____ Elevation drawing of all water features noting height, i.e. Waterfalls, walls, slides, etc.

_____ Fence plan, showing existing fence, new fence lines, type, height of fence.

_____ **Show construction access to rear property.** .

_____ Exposed foundations up to twelve inches (12") in height must be finished with plaster, underpinning, or stucco in a color that matches or compliments the color of the pool decking and/or stone.

_____ Any area of exposed foundation in excess of twelve inches (12") in height must be faced with brick, stone or similar material that matches or blends with the color of the materials utilized on the pool and/or house. At their discretion, the Architectural Committee (AC) may require additional screening with evergreen landscaping.

_____ Cross-section showing existing and proposed finished grades of lot in relation to the pool.

_____ Location of pool equipment, including dimensions to nearest property lines, and details of screening (if applicable).

_____ Location and type of decking to be used. Please note elevation changes to existing and finished grades.

Coping Material: _____ Spa Description (if applicable): _____

Tile Color: _____

Deck Material: _____

Deck Stain Color (wood decks only): _____ Waterfalls, Slides, etc. Description (if applicable): _____

Veneer finish & color: _____

Home Owner must contact the Association's Office for first inspection (pre-gunite inspection) prior to gunite.

The AC may request that you provide additional information before acting upon your request. The application is not complete until all information requested has been received. All modifications must comply with applicable deed restrictions and design guidelines. Please allow at least ten (10) working days to receive determinations back from the committee. Please call (512) 266-7553 if you have any questions.

Owner Name (Print)

Signature of Owner



**Steiner
Ranch**

**STEINER RANCH MASTER ASSOCIATION (SRMA) AND
STEINER RANCH RESIDENTIAL OWNERS ASSOCIATION (SRROA)
ARCHITECTURAL COMMITTEES
GREENBELT ADDENDUM**

Applicant Name: _____ **Date Submitted:** _____

Property Address: _____

Applicant Contact Phone Numbers: _____

Applicant E-mail Address: _____

Contractor Name (if applicable): _____

Contractor Address & Phone/Fax Number (if applicable): _____

Requesting access to greenbelt area at: _____

Purpose of accessing greenbelt area: _____

Time period for which access is requested: _____

Temporary construction access through the greenbelt is reviewed on a case-by-case basis. All other options must be exhausted before the construction access through a greenbelt will be allowed. Access is *only* granted for purposes of excavation and moving materials. Under no circumstances should the greenbelt be used for storing materials or parking vehicles. A minimum deposit of \$1000.00 is required before access will be granted and this check *will* be deposited. The existing condition of the greenbelt will be documented before access will be granted, and it is suggested the applicant document the condition as well. The deposit will be refunded at the time the applicant/owner and his contractors have vacated the area and have returned the area to its previous condition.

Applicant Name (Print)

Signature of Applicant

GREENBELT ACCESS IS: Granted Not Granted

ACCESS START & END DATES: _____

AC Representative

AC Representative

AC Representative



**STEINER RANCH MASTER ASSOCIATION (SRMA) AND
STEINER RANCH RESIDENTIAL OWNERS ASSOCIATION (SRROA)
ARCHITECTURAL COMMITTEES
VARIANCE REQUEST FORM**

Applicant Name: _____ **Date Requested:** _____

Applicant Address: _____

Applicant Contact Phone Numbers: _____

Requesting variance for the following address: _____

Reason for variance: _____

Justification for variance: _____

Date by which variance is needed: _____

Please submit this form, pictures or detailed drawing and all applicable documentation to justify the variance request. **You must explain why your request is unique and should be granted.**

ALL VARIANCE REQUESTS MUST BE SUBMITTED A MINIMUM OF SEVEN DAYS BEFORE VARIANCE IS NEEDED. IF A VARIANCE IS REQUIRED AND SEVEN DAYS NOTICE IS NOT GIVEN, A \$100.00 FEE WILL APPLY FOR PROCESSING.

Applicant Name (Print)

Signature of Applicant

VARIANCE IS: Granted Not Granted DATE: _____

AC Representative

AC Representative

AC Representative

STEINER RANCH IPM PLAN OUTLINE

April 2001

PROJECT DESCRIPTION

- 1) Project Name: Steiner Ranch
- 2) Project Type: 4,800-acre mixed-use residential and commercial Master Planned Community.
- 3) Landscape:
 - a. Turf Acreage: It is estimated that turf (lawn) areas will total 1,500 acres at build-out.
 - b. Ornamental Acreage: It is estimated that ornamental landscape areas will total 800 acres at build-out.
 - c. Greenbelts/Open Space: Approximately 1,700 acres will remain as undeveloped natural areas, primarily in the steeply sloping ravines that run through the property.
 - d. Total Project Acreage: The total acreage of property being developed is approximately 3,100 acres. The overall impervious cover percentage upon completion will be less than 20%.
- 4) Environmental Features:
 - a. Environmental Features: Key environmental features within Steiner Ranch include canyon rim rocks and wet weather seeps, typical of this area. In addition, the developer has set aside 819 acres within the greenbelt areas as a conservation easement for the Golden Cheeked Warbler and the Black Capped Vireo, two endangered songbirds known to nest in this region.
 - b. Pesticide/Fertilizer Buffers: The conceptual master plan for Steiner Ranch shows the considerable natural open space and greenbelt areas within the community that serve as natural buffers for the treatment of pesticide/fertilizer run-off from the development areas before the run-off reaches Lake Austin.

ANTICIPATED PEST PROBLEMS

Potential pests requiring treatment in Steiner Ranch include: fire ants, fleas, mosquitoes, roaches, rodents and termites. In addition, turf grass lawns and landscaping will require treatment for weeds, diseases and insects.

TREATMENT STRATEGY

Attached are descriptions of the above listed pests and the recommended steps that should be taken to control them. The treatment and control strategies are laid out in a hierarchy from least invasive to most. Non-toxic and less persistent control products or procedures should be employed before more persistent products are considered.

IPM PLAN for
FIRE ANTS
(6/26/00)

1. Pest to be controlled: red imported fire ants
2. Biology of the red imported fire ant, Solenopsis invicta:

The red imported fire ant is a tropical insect that was accidentally introduced into the United States in the 1930s and has spread unchecked across the Southeast and into Texas. Fire ants disperse naturally through mating flights that usually occur in the spring and fall, but may occur anytime warm humid conditions exist, even during the winter. Fire ant queens are also dispersed by the movement of infested nursery stock and turf sod, and even by vehicles. Fire ant colonies are known to raft to higher ground during floods. The most visible indication of the presence of fire ants is their characteristic cone-shaped mounds.

The only way to effectively control or suppress fire ants is to use a method that will stop egg production by the queen(s). Killing workers will have no lasting effect on the fire ant colony. Therefore the use of granular insecticides, which frequently do not come in contact with the queen, is not a long-term solution. The ineffective use of pesticides, especially in environmentally sensitive areas, should be avoided.

3. Control tactics:
 - a. Physical control tactics will include the use of hot water to drench individual fire ant mounds. Mounds will be drenched mid-morning with at least a gallon of hot water on the sun-side of the mound in an attempt to kill queen(s). Drenched mounds will be rebuilt by surviving workers, but the colony will soon disperse if the queen is killed. If mounds persist, it will prompt the use of the next control tactic.
 - b. There are no mechanical control tactics available to control fire ants.
 - c. Biological control tactics include the use of nematodes, which are slender, microscopic, unsegmented worms. This nematode has been cultured to hunt, seek, and destroy soil-boring fire ants by invading ant colonies.

| Active Ingredient | Product Name |
|---|-----------------|
| Neopleotana Carpocapsae (nematode) | ANTidote |

- d. Non-toxic and less persistent control tactics include the broadcast of fire ant baits. Fire ant baits are designed to be attractive to foraging fire ants and eventually become passed to the queen(s). The effect of the bait will be to neutralize the queen by stopping egg production. Because fire ants will not forage when ground temperature is below 70° or above 95°, and because the baits will not remain attractive if wet, care shall be taken to apply the baits when the soil and vegetation are warm and dry. Apply baits when no rain is expected for at least 8 hours. In summer, apply baits in the evening, since ants do not forage during extreme heat. As fire ant baits require several weeks or more to affect

colonies, the next control tactic will only be prompted by the persistence of active mounds over a long period.

| Active Ingredient(s) | Product Name |
|-----------------------|------------------------|
| Fenoxycarb | Logic® |
| Hydramethylnon | Amdro®, Combat® |
| Spinosad | Eliminator® |
| Methoprene | Extinguish™ |
| Abamectin | Ascend™, Raid® |
| Pyriproxyfen | Spectracide® |

- e. More persistent chemical control tactics will include the use of liquid drenches or dusts that kill ants on contact. These products are appropriate for individual mound treatments only.

| Active Ingredient | Product Name |
|---|---------------------------|
| d-limonene | Citrex™ |
| Pyrethins, silicon dioxide, and piperonyl butoxide | Organic Solutions™ |

4. This IPM plan is a dynamic document. If other control tactics are found effective, then this plan will be amended to include those tactics. No regularly scheduled pesticide applications are planned.

IPM PLAN for
FLEAS
(6/26/00)

1. Pest(s) to be controlled: fleas.
2. Biology of the cat flea, Ctenocephalides felis:

Fleas are associated with warm-blooded animals and pass through four life stages: egg, larva, pupa, and adult. Optimal flea development is at 65 to 80 degrees F. with a relative humidity of 70%. Hot dry summers reduce flea populations while cool rainy weather increases populations. When adult fleas emerge from pupae, they immediately seek a blood meal from warm-blooded animals. After mating, females lay eggs on hosts or on their sleeping areas. Eggs hatch into larvae within 12 days and usually feed on organic debris for 8-24 days. Pupae usually emerge into adults in 5-7 days. If conditions for development are unfavorable, larvae can live for up to 200 days and pupae for up to one year. An effective control strategy is to arrest flea development before the pupal stage to prevent explosive population growth when optimal conditions occur.

3. Control tactics:

- a. Physical control tactics will include combing and bathing of pets, and vacuuming or washing of rugs, carpets, furniture and pet sleeping areas. The number of fleas captured in combs is to be used as an indicator of the overall flea population and should be monitored. When fleas reach annoying levels, an increase in fleas captured in combs prompts the next control tactic.
- b. Mechanical control tactics will include the screening of pets from areas where fleas congregate or where vacuuming or washing would be difficult. If flea monitoring indicates mechanical controls have not decreased the flea population, then next control tactic is prompted. Note: Some non-toxic control products work mechanically, but are included in the non-toxic category.
- c. **Biological control tactics include the use of nematodes, which are slender, microscopic, unsegmented worms. This nematode has been cultured to hunt, seek, and destroy specific soil-borne insects.**

| Active Ingredient | Product Name |
|---|------------------|
| Neopleotana Carpocapsae (nematode) | ANTidote™ |

- d. Non-toxic and less persistent control tactics will include dusting pets, and the places they inhabit, with products containing pyrethrum, silica aerogel, or diatomaceous earth. Yards or other outdoor areas inhabited by pets will be sprayed with products containing insecticidal soap, pyrethrum, or rotenone. Higher concentrations of fleas may occur in

the shady areas versus the dry sunny areas. An insect growth regulator will be added to the spray before application.

| Active Ingredient(s) | Product Name |
|---|----------------------|
| Silica aerogel, pyrethrins, and piperonyl butoxide | Drione® |
| Pyrethrins, piperonyl butoxide, and diatomaceous earth | Permagard® |
| Insecticidal soap | Safer's Soap® |
| Pyrethrins, piperonyl butoxide, and rotenone | Organocide® |
| Fenoxycarb | Torus® |

e. More persistent chemical control tactics will include using pet collars containing organophosphates, and the use of pyrethroids to control fleas outside.

| Active Ingredient | Product Name |
|-------------------|---------------|
| Dichlorvos | Hartz® |
| Permethrin | Flee® |

4. This IPM plan is a dynamic document. If other control tactics are found effective, then this plan will be amended to include those tactics. No regularly scheduled pesticide applications are planned.

IPM PLAN for
MOSQUITOES
(6/26/00)

1. Pest(s) to be controlled: mosquitoes
2. Biology of the mosquito, Order Diptera, Family Culicidae:

Adult mosquitoes are small, slender, long-legged flies with a long piercing mouthpart called the proboscis. Mosquitoes develop through four distinct stages: egg, larva, pupa, and adult. Adult females feed on animal blood for the protein needed to produce eggs. Eggs are laid singly or in clumps on still or slow-moving water. Some mosquitoes lay eggs in temporary water basins such as tree holes or at the edges of flood prone areas.

Mosquito eggs may lie dormant for months before hatching, but under most circumstances hatch within 2 to 6 days. The aquatic larva and pupa stages each take from 4 to 10 days to develop and represent the most vulnerable stages. Adults can live up to 2 months after emergence. Most mosquitoes die within yards of where they emerged.

The most effective method of controlling mosquitoes is to limit the number of water basins where eggs can hatch. Examples of temporary basins include cans and jars, clogged roof gutters, used tires, plant saucers, plastic sheeting, and wheelbarrows. Larger, more permanent water basins can be drained or filled in. However, not all water basins can or should be altered for environmental reasons. In addition, the excessive use of fertilizers should be discouraged as fertilizers in water will promote algae blooms that protects the mosquitoes from predation by fish.

3. Control tactics:
 - a. Physical control tactics will include the use of screens on windows and doors. Electric "bug zappers" will not be used, as they are not effective at reducing mosquito populations since they target only adults, and affect non-target insect populations as well.
 - b. Mechanical control tactics will include the use of suffocating surface film where practical. This will include those basins not subject to runoff. The films to be used are highly refined and biodegradable, with no effect on human or non-target species.
 - c. Biological control tactics will include the use of native mosquito-eating fish (*Gambusia*) in permanent pools, where a viable fish population can be maintained.
 - d. Least toxic and less persistent chemical control tactics will include the use of Bacillus thuringiensis israelensis or pyrethrum larvicides. These products will be applied to water basins where mosquito larvae develop.

| Active Ingredient(s) | Product Name |
|---|------------------------|
| Bacillus thuringiensis israelensis | Mosquito Dunks® |
| Encapsulated pyrethrum | Tossits® |

4. **This IPM plan is a dynamic document. If other control tactics are found effective, then this plan will be amended to include those tactics. No regularly scheduled pesticide applications are planned.**

IPM PLAN for
ROACHES
(6/26/00)

1. Pest(s) to be controlled: cockroaches

2. Biology of the German cockroach, Blattella germanica:

There are five species of cockroaches that commonly infest houses, with the German cockroach being one of the most widely distributed. Roaches are tropical insects that have adapted to living with man by seeking areas where they can get warmth and moisture, such as bathrooms and kitchens. Female roaches glue egg cases, called ootheca, to the surfaces of any dark place. The average development time for the German cockroach from egg to adult is 55-68 days. Adults can live more than 200 days. They are active at night.

3. Control tactics:

- a. Physical control tactics will include the sealing of cracks and crevices and the screening of windows and vents to limit access from the outside. Roach traps will be used to monitor to pest population.
- b. Cultural control tactics will include good sanitation, including the proper storage of food and regular cleaning.
- c. There are currently no biological control tactics available for control of cockroaches.
- d. Non-toxic and less persistent control tactics will insecticidal dusts and baits, and insect growth regulators.

| Active Ingredient(s) | Product Name |
|------------------------------|--------------|
| Boric acid powder | Roach Rid® |
| Silica aerogel and Pyrethrum | Drione® |
| Hydramethylnon | Combat® |
| Hydroprene | Gencor™ |

4. This IPM plan is a dynamic document. If other control tactics are found to be effective, then this plan will be amended to include those tactics. No regularly scheduled pesticide applications are planned.

IPM PLAN for
RODENTS
(6/26/00)

1. Pest(s) to be controlled: rodents.
2. Biology of the common house mouse, Mus musculus, roof rat, Rattus rattus and Norway rat, Rattus norvegicus:

The house mouse, roof and Norway rats are rodents intimately associated with people, and are found almost everywhere humans live or work. While wild mice and rats will invade houses when weather changes, these pests are dependent on man for shelter and food. The reproductive rate of rodents in general and mice in particular is very high. Female mice produce 10 litters a year, 6-7 young per litter. Rats are almost as productive, but suffer high mortality. All rodents respond to trapping or other declines in their population by producing more litters.

Strategies to control rodents involve primarily preventative steps to limit access to shelter and food, trapping to reduce small populations, and poisoning.

3. Control tactics:
 - a. Physical control tactics will include the filling of access holes, making food storage rodent-proof, and the use of barriers. These measures will include the inspection of sewer lines into dwellings and cracks in foundations.
 - b. Mechanical control tactics will include the trapping of rodent populations in snap traps or glue boards. A large number of traps will be placed to have the desired effect on the population.
 - c. The use of domestic cats will be considered as a biological control tactic, if they will not become pests themselves.
 - d. Non-toxic and less persistent control tactics will include the use of cholecalciferol, which will not lead to secondary poisoning.

| Active Ingredient(s) | Product Name |
|----------------------|--------------|
| Cholecalciferol | Quintox® |

- e. More persistent chemical control tactics will include the use of anticoagulants placed in bait boxes to prevent secondary poisoning.

| Active Ingredient(s) | Product Name |
|-------------------------------|--------------|
| Warfarin and Sulfaquinoxaline | Prolin® |

4. This IPM plan is a dynamic document. If other control tactics are found effective, then this plan will be amended to include those tactics. No regularly scheduled pesticide applications are planned.

IPM PLAN for
TERMITES
(6/26/00)

1. Pest(s) to be controlled: termites.
2. Biology of the eastern subterranean termite, Reticulitermes flavipes:

Subterranean termites are social insects that live in colonies of winged reproductives, sterile workers and soldiers. Overcrowded conditions prompt reproductives to swarm, usually during the first warm humid days of spring. Winged termites are often confused with ants but their equal-sized pair of wings can identify them. It is important that a positive identification be made of suspected termite infestations. Subterranean termites are different from other termites in that they must have regular contact with moisture. This is generally accomplished by building earthen tubes to the soil. Water leaks in structures provide a good environment from which termites can build tubes. In most structures, these tubes are visible on exterior walls, but they may be present on interior walls as well if termites have gained access through cracks in slabs.

The important first step in a termite control program is the elimination of conditions that favor termite survival. These steps include the removal of wood debris around structures, eliminating areas of earth-to-wood contact and constructing barriers to termite entry. It is also important to regularly monitor structures for signs of moisture, damaged wood, or earthen termite tunnels and to act only if these signs are present. The most vulnerable stages of the termite colony are the eggs and immatures.

3. Control tactics:
 - a. Physical control tactics will include the plugging of cracks and crevices in structures that may provide access. Any exterior feature that leaks water such as guttering and water pipes will be repaired. Physical controls also include the use of a stainless steel wire mesh perimeter barrier around the building. Installers should be trained and accredited for quality control.

| Material | Product Name |
|--|--------------------|
| 316 marine grade stainless steel w/appropriately-sized aperture | Termi-Mesh™ |

- b. There are no mechanical control tactics currently available to control termites. However, sand barriers have been tested as a deterrent to tunneling and may soon be recommended as a control alternative.
 - c. There are no biological control tactics currently available to control termites.
 - d. Least-toxic chemical control tactics will involve the use of insect growth regulators (used as baits) and/or chemical barriers that are undetectable by termites.

| Active Ingredient | Protection Method | Product Name |
|-------------------|-------------------|--------------|
|-------------------|-------------------|--------------|

| | | |
|---------------------|--------------------------------|-------------------|
| Fenvalerate | Chemical barrier | Pydrin™ |
| Imidacloprid | Chemical barrier | Premise® |
| Hexaflumuron | Insect growth regulator | Sentricon™ |

4. This IPM plan is a dynamic document. If other control tactics are found effective, then this plan will be amended to include those tactics. No regularly scheduled pesticide applications are planned.

IPM PLAN for
TURFGRASS
(6/26/00)

1. Pests to be controlled: turfgrass weeds, diseases, and insects
2. Integrated Pest Management (IPM) of turfgrass involves the use of multiple control tactics to keep selected pests below an acceptable injury level. IPM has a series of responsibilities, the primary one being the proper identification and understanding of the pest. Selected pests are only those which pose a threat to turf quality. Common turfgrass pests are weeds (including crabgrass, and dallisgrass), diseases (including brown patch, dollar spot, and pythium blight), and insects (including fire ants, mole crickets, sod webworms, and armyworms).

The tactics included in this IPM plan are: a.) physical, b.) cultural, c.) biological, and d.) chemical. The goal of the IPM plan is to emphasize the physical, cultural and biological tactics and minimize chemical use, thereby lessening the effects on the hydrologic system.

3. Life cycle of pests:
 - a. Crabgrass (*Digitaria* spp.): Crabgrass is an annual grass spread primarily by seed and to a minor extent by rooting from lower nodes. Crabgrass is a short, bunching, leafy grass, light green in color. It is frequently found in over-watered turf and/or compacted soils.
 - b. Dallisgrass (*Paspalum dilatatum*): Dallisgrass is a warm-season annual grass. It is a coarse-textured, bunch-type grass that spreads primarily by seed. Lower leaves may be hairy, while all are noticeably shiny. The seed stalks of dallisgrass are sparsely branched on long stems, and contrast dramatically in desired turf.
 - c. Brown Patch (*Rhizoctonia* spp.): Brown patch is a fungal disease most likely to damage bermudagrass and St. Augustinegrass in the spring or fall. Areas of turf affected with brown patch consist of irregular brown areas that range from a few inches to many feet in diameter. Environmental conditions that favor disease development are day temperatures above 85°F, high relative humidity, and prolonged overcast wet periods. Excessive nitrogen fertilization and frequent irrigation also favor development.
 - d. Dollar spot (*Sclerotinia homoeocarpa*): Dollar spot in turf consists of small circular areas about 2 inches in diameter, which are brown or straw in color. Moderate temperatures (60° to 80° F), excess moisture and excess thatch lead to development of this disease, especially on closely cut turf.
 - e. Pythium blight (*Pythium* spp.): Pythium blight kills turf in small irregular spots. The fungi produce spores that survive for long periods in the soil, but develop rapidly with excessive moisture. Blackened leaves of affected grasses wither rapidly and turn reddish brown. At high temperatures, severe damage can occur in low areas of consistently wet turf.
 - f. Fire ants (*Solenopsis invicta*): The red imported fire ant is a tropical insect that was accidentally introduced into the United States in the 1930's. Fire ants disperse naturally through mating flights, which usually occur in the spring and fall. Fire ants are often moved in soil, sod, and containerized plants. Fire ants do not attack turf, but cause problems when they build earthen mounds for warming their eggs, larvae, and pupae. Mounds may be built in any turf situation. Established colonies produce new queens and workers that, if left uncontrolled, will eventually lead to large populations and additional mounds. Refer to the individual IPM plan on fire ants for specific control measures.
 - g. Mole crickets (*Scapteriscus acletus*): Mole crickets have grayish brown, velvety bodies with broad spade-like front legs adapted for digging. Adults spend the winter in deep burrows. When the soil warms, they move up to dig in grass and feed on turf insects. In the late spring and early summer, mole crickets fly and mate. Females lay eggs in chambers beneath the soil. The eggs hatch in May and June, with any tunneling caused by the young nymphs obvious by late July. The most vulnerable stage of the mole cricket is the nymphal stage with earlier treatments

ineffective. Treatment will be made only if damage is noticeable and verified by a soap flush. A proposed injury level is 3 nymphs per square feet.

- h. Sod webworms (*Crambus* spp.): Sod webworms are the larval form of lawn moths. Larvae are slender grayish, black-spotted caterpillars about $\frac{3}{4}$ inch long. Adults are small and vary in color from white to gray. Moths hide during the day, but after mating, drop their eggs over grass at dusk. Eggs hatch in a few days and larvae begin to feed. They pupate in silken tunnels found in the soil/thatch layer. There are 2-4 generations a year with the last spending the winter in the larval stage. Grasses are most susceptible July through September. The presence of larvae is verified by a soap flush with a proposed injury level set at 15 or more per square yard.
- i. Armyworms (*Psuedaletia* spp.): Armyworms are the larval form of moths and thus have complete life cycles with eggs, larvae, pupae, and adults. They are dull brown, tinged with red, and thick-bodied. Adults fly at night and lay eggs at the base of grasses or nearby plants. Armyworms feed at night, hiding in thatch during the day. Generations overlap, with as many as six generations a year. The presence of armyworms is verified by soap flush with a proposed injury level set at 5 per square feet.

4. Control tactics:

- a. Physical control tactics include simply removing the pests by hand, trapping, or mowing the pests. Weeds can be physically removed with the help of hand-tools.
- b. Cultural control tactics are those that maintain the quality of turfgrass by providing the best possible growing conditions. These practices are constantly monitored, evaluated, and adjusted for their direct effect on turf quality and the reduction of pest populations. To achieve quality turf grass, and minimize the need for synthetic fertilizer and pesticides, the following practices will be used:
 - 1.) Irrigation: The goal with turfgrass irrigation should be to maximize the efficient use of water and minimize any irrigation runoff. If an automatic irrigation system is used, it should be visually monitored while in use on a regular basis. Spray heads should be adjusted to prevent over-spray onto pavement, and any broken heads should be fixed promptly. Over-watering can lead to turfgrass disease; therefore the watering schedule should be adjusted regularly to fit the prevailing weather conditions. Irrigation at dawn allows for drying of the leaf surface before nighttime, thus minimizing the opportunity for disease.
 - 2.) Mowing: Mowing should occur on a regular basis, and no more than one-third of the leaf blade should be removed at a time. Grass clippings should not be bagged, and any grass clods resulting from mowing should be scattered. Clippings will return nitrogen back to the soil as they decompose, minimizing the need for fertilization. To minimize the opportunity for plant disease, avoid mowing wet foliage, keep mowers adjusted and blades sharp. Maintain a high mowing height within a species' adapted range. Raise the mowing height during periods of environmental stress or disease outbreaks. Weeds should always be mown before seed is produced.
 - 3.) Top dressing: Top dressing (spreading a thin layer of compost or other organic matter on the turf) is an effective way to fertilize the soil and control thatch. Control of thatch will reduce the chance for disease and improve water filtration. Thatch is a layer of dead leaves and stems held together by grass roots and stolons. Though a thin layer of thatch seems to be beneficial to the growth of turf, thick layers can cause the turf to grow aboveground and can contribute to disease and insect problems. Thatch can severely restrict the movement of pesticides. Top-dressing with compost may reduce the severity of certain plant diseases.
 - 4.) Aerification: Aerification is the process of de-compacting the top few inches of soil by removing soil cores or simply punching holes into the soil. This practice increases water infiltration, relieves soil compaction, and accelerates decomposition of the thatch layer.
 - 5.) Fertilization: The nutrient requirements of turf grass vary with the amount of organic matter in the soil and the amount of water received. The amount and frequency of fertilizer use will be dependent on an analysis of the soil. A 3-1-2 ratio of macronutrients (N-P-K) is usually best. Granular fertilizers will be slow-release (a.k.a. timed-release). Top-dressing with organic fertilizer is ideal. Slow-release and organic fertilizers shall be lightly irrigated to

incorporate the nutrients into the soil and make them less available for runoff. Fertilizers shall not be applied during wet weather or when rainfall is imminent. Fertilizers shall not be applied within any environmentally sensitive areas, or within 50' of a waterway.

- 6.) Overseeding: Overseeding of turfgrass with a cool-season grass while the warm-season grass is dormant may inhibit weed germination.
 - 7.) Disease-resistant species: Plant disease-resistant species and cultivars whenever possible. Recommendations for regionally adapted cultivars can be obtained from most Cooperative Extension Service offices.
 - 8.) Night lighting: Since the adults (moths) of sod webworms and armyworms are attracted to lights at night and they oviposit nearby, place lights away from sensitive turf areas. Lights with the yellow range are also much less attractive to night flying insects.
- c. Biological control tactics for fire ants will include the use of nematodes. Nematodes (*Neopleotana Carpocapsae*), which are slender, microscopic, unsegmented worms, may be applied over the turf during the warm season to control soil dwelling insect pests. Best results are obtained by applying the nematodes in the late afternoon, just before sunset.

| Insect | Active Ingredient(s) | Product Name |
|------------------|---------------------------------------|------------------|
| Fire Ants | <i>Neopleotana Carpocapsae</i> | ANTidote® |

- d. **Chemical control tactics may include the use of herbicides, fungicides, and/or insecticides. The user shall be a qualified applicator, shall read the product label, and shall strictly follow manufacturer's directions. Chemical control of weeds will be limited to spot treatment with the use of a non-selective post-emergence herbicide. Pre-emergence herbicides will not be used. The use of each chemical will be re-evaluated every year so that the most effective and most environmentally sensitive products will be used.**

1.) **Herbicide List:**

| Weeds | Active Ingredient | Product Name |
|--------------------|-------------------|-----------------|
| Crabgrass | Glyphosate | Roundup® |
| Dallisgrass | Glyphosate | Roundup® |

2.) **Fungicide List:**

| Disease | Active Ingredient | Product Name |
|-----------------------|----------------------|----------------|
| Brown Patch | Propiconazole | Banner® |
| Dollar Spot | Propiconazole | Banner® |
| Pythium Blight | Metalaxyl | Subdue® |

3.) **Insecticide List:**

| Insect | Active Ingredient(s) | Product Name |
|----------------------|---|-----------------|
| Mole Crickets | Fluvalinate | Mavrik® |
| Sod Webworms | <i>Bacillus thuringiensis (BT)</i> | Dipel® |
| Armyworms | Azadirachtin | Turplex® |

5. This IPM plan is a dynamic document. If other control tactics are found effective, then this plan will be amended to include those tactics. No regularly scheduled pesticide applications are planned. Please note that no endorsement of named products is intended, nor is criticism implied for products that are not mentioned.

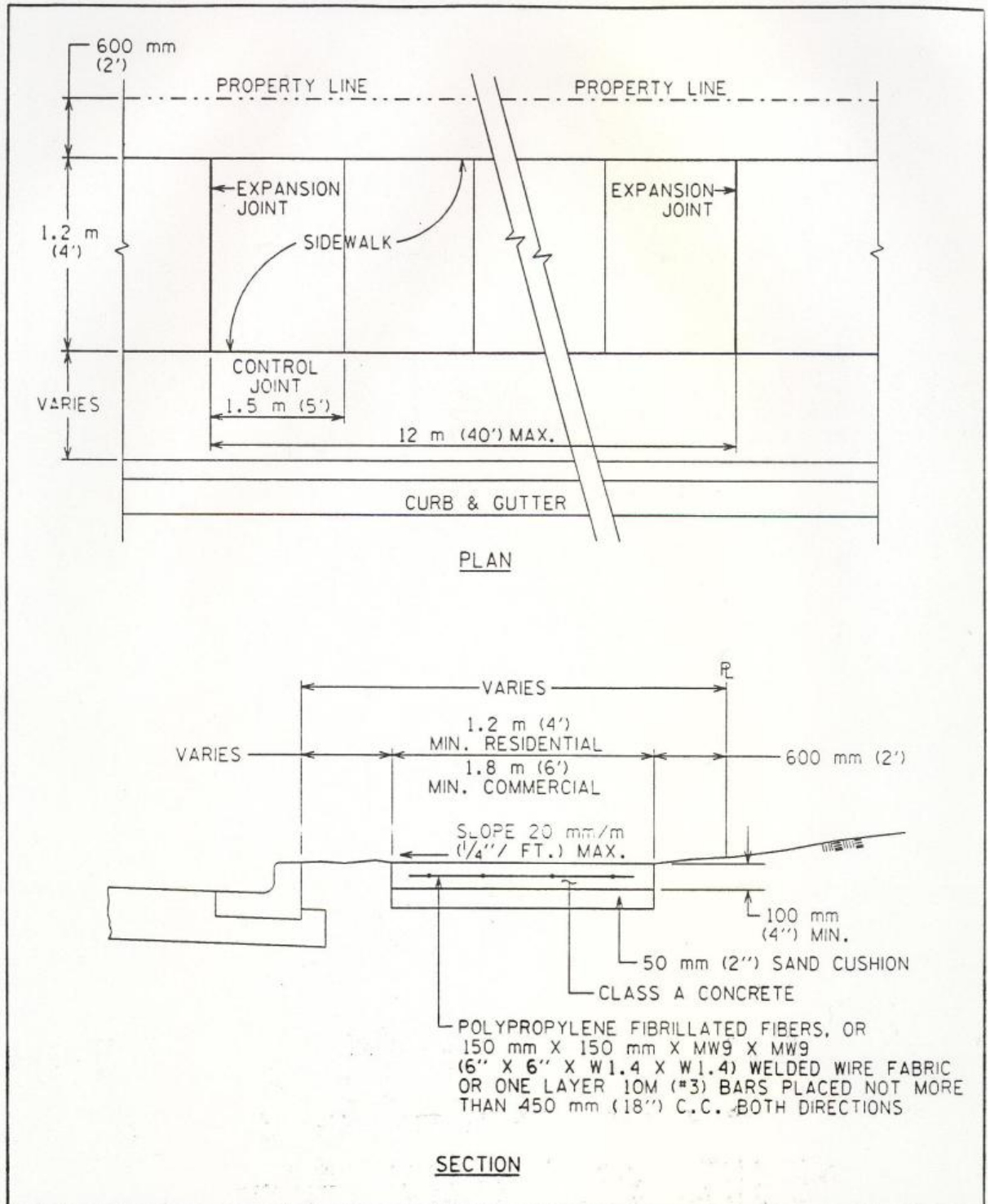

| | | |
|---|--|---------------------|
| <p>CITY OF AUSTIN DEPARTMENT OF PUBLIC WORKS AND TRANSPORTATION</p> | <p>SIDEWALK.</p> | <p>STANDARD NO.</p> |
| <p><i>Luis Loria</i> 9/29/99 ADOPTED</p> | <p>THE ARCHITECT/ENGINEER ASSUMES RESPONSIBILITY FOR APPROPRIATE USE OF THIS STANDARD.</p> | <p>432S-1</p> |

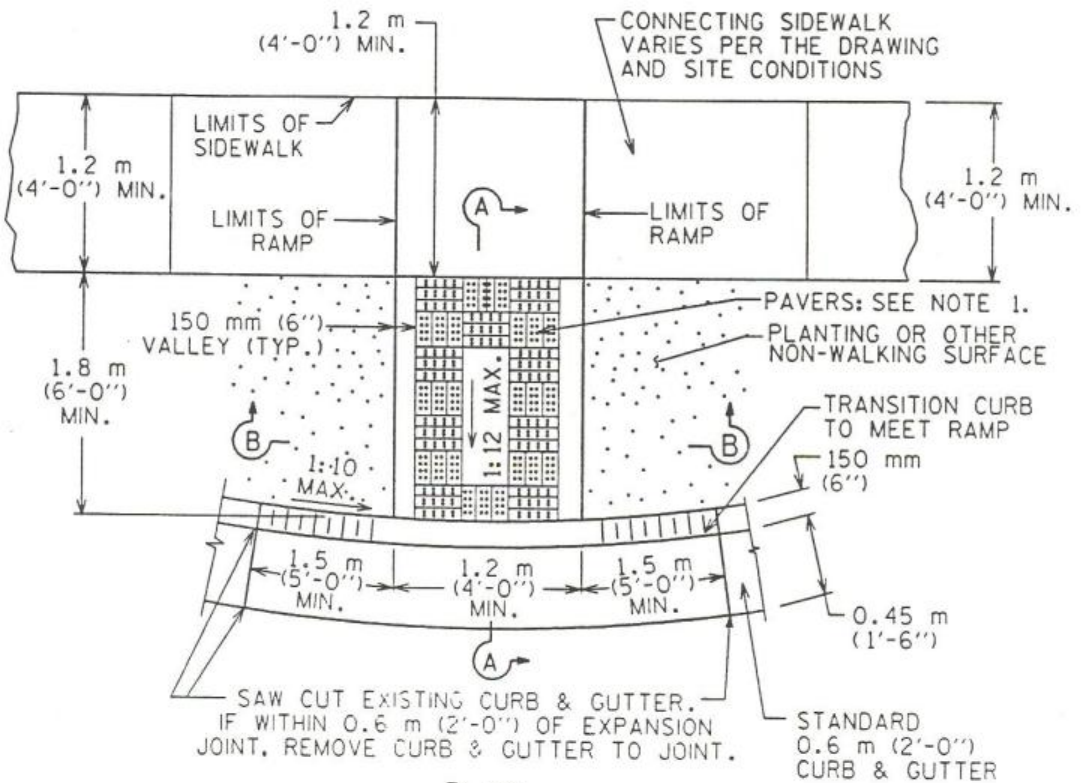

PLAN

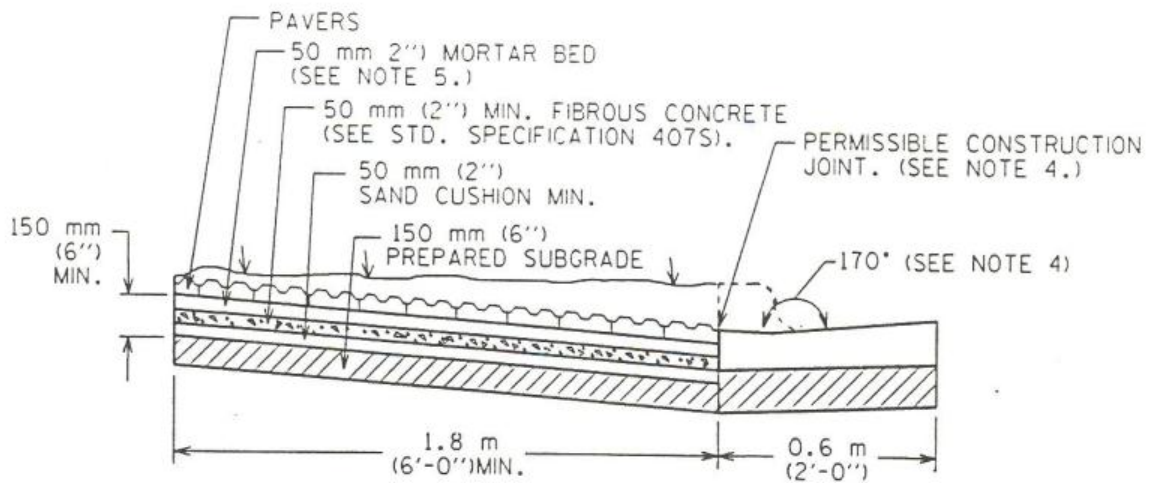

SECTION A-A

CITY OF AUSTIN
DEPARTMENT OF PUBLIC WORKS AND TRANSPORTATION

SIDEWALK CURB
RAMP WITH PAVERS (TYPE 1B)

Leno Ferris 4/5/99
ADOPTED

THE ARCHITECT/ENGINEER ASSUMES
RESPONSIBILITY FOR APPROPRIATE USE
OF THIS STANDARD.

STANDARD NO.
432S-5B
1 OF 2

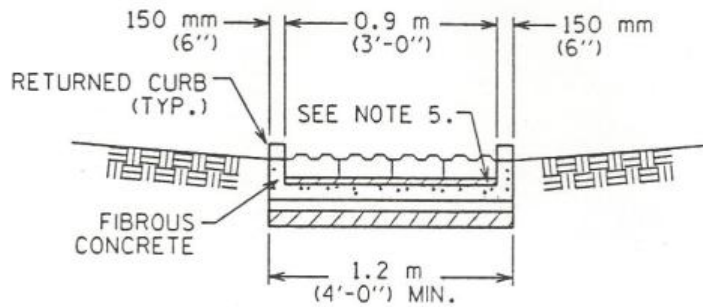

SECTION B-B

GENERAL NOTES :

1. Pavers will have detectable warning that consists of raised truncated domes with a diameter of 23 mm (0.9"), a nominal height of 5 mm (0.2") and a nominal center-to-center spacing of 60 mm (2.35") and shall contrast visually with adjoining surfaces, either light-on-dark or dark-on-light (RE: ADA Section 4.29.2). Material used to provide contrast shall be an integral part of the walking surface. Paver pattern varies per manufacturer's recommendation.
2. The ramp wings do not have to display contrasting color.
3. Typical sidewalk widths and curb radii are shown for illustration. Refer to the Transportation Criteria Manual for sidewalk widths, curb radii and curb basis.
4. The permissible construction joint between the brick pavers and the laydown curb shall be limited to 6 mm (1/4") joint size. Gaps larger than 6 mm (1/4") must be approved by the Project Manager/Inspector. Gaps greater than 6 mm (1/4") shall be solid mortar filled between the brick pavers and curb unless otherwise instructed by the Project Manager/Inspector.
5. Mortar shall conform to Item 403.2 (6)/403S.2 (6) Mortar (Grout). All other concrete shall conform to Item 403/403S, "Concrete for Structures" unless noted otherwise.
6. Curb ramps with 150 mm (6") concrete valley may only be used where pedestrians would not normally walk diagonally across the ramp.

| | | |
|--|---|--|
| CITY OF AUSTIN DEPARTMENT OF PUBLIC WORKS AND TRANSPORTATION | SIDEWALK CURB RAMP WITH PAVERS (TYPE 1B) | STANDARD NO. 432S-5B 2 OF 2 |
| <i>Luis Rocio</i> 4/5/99 ADOPTED | THE ARCHITECT/ENGINEER ASSUMES RESPONSIBILITY FOR APPROPRIATE USE OF THIS STANDARD. | |

REV. DATE: 2/27/97 DESCRIPTION: STANDARD MANUAL

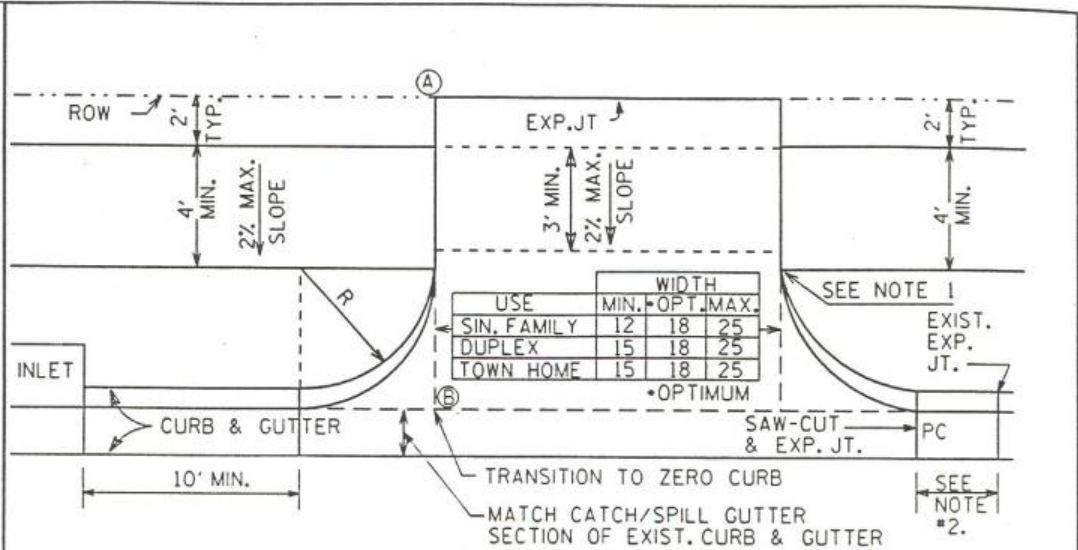

PLAN

RADIUS DIMENSION

| USE | MIN. | •OPT. | MAX. |
|---------------|------|-------|------|
| SINGLE FAMILY | 5 | 5 | 10 |
| DUPLEX | 5 | 8 | 10 |
| TOWN HOME | 5 | 8 | 10 |

•OPTIMUM

NOTE: ALL DRIVEWAYS SHALL BE SLOPPED TOWARDS THE STREET FROM THE R.O.W. LINE. ELEVATION OF POINT (A) ABOVE POINT (B) IS, TYPICALLY, A MINIMUM OF 6" PLUS 1/4" RISE/FEET OVER (A)

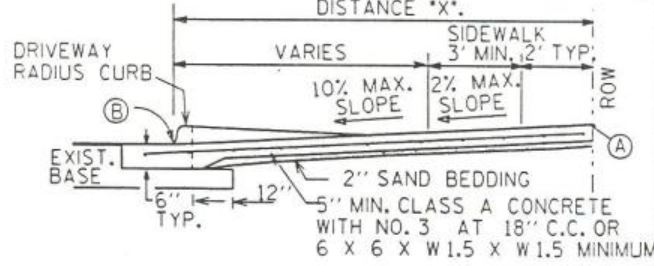

CROSS SECTION

| DRIVEWAY VOLUME (ADT) | D=GRADE CHANGE | |
|-----------------------|----------------|------|
| | STD. | MAX. |
| > 1500 | 0% | 3% |
| 500-1500 | 3% | 6% |
| < 500 | 6% | 15% |

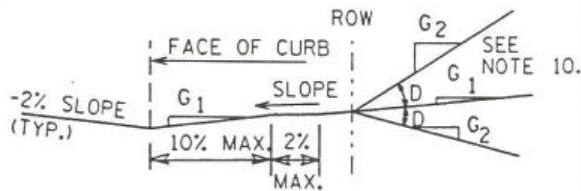

ALLOWABLE GRADES

| | |
|--|---|
| CITY OF AUSTIN DEPARTMENT OF PUBLIC WORKS AND TRANSPORTATION | TYPE I DRIVEWAY (1 & 2 FAMILY RESIDENTIAL USE ONLY) |
| <i>Law Rivera</i> APPROVED | 7-15-97 DATE |
| ADOPTED: 11-22-95 SCALE: N.T.S. INITIAL: H.D.T. | STANDARD NO. 433-1 1 OF 2 |

GENERAL NOTES :

1. "ZERO" CURB AT PT OR SIDEWALK EDGE, WHICHEVER IS ENCOUNTERED FIRST. THE DRIVEWAY EDGE SHALL BE SMOOTHLY TRANSITIONED INTO THE SIDEWALK BEGINNING AT THE RADIUS PC LINE. FLARED DRIVEWAYS ACCEPTABLE ON LOCAL STREETS ONLY.
2. IF DIMENSION IS LESS THAN FIVE FEET, REMOVE CURB & GUTTER TO EXISTING EXPANSION JOINT AND POUR MONOLITHICALLY WITH THE DRIVEWAY.
3. IF THE BASE IS OVER-EXCAVATED WHERE THE CURB & GUTTER WAS REMOVED, BACKFILL WITH CONCRETE MONOLITHICALLY WITH THE DRIVEWAY.
4. ALL DRIVEWAYS MUST BE CONSTRUCTED WITHIN THE STREET FRONTAGE OF THE SUBJECT PROPERTY AS DETERMINED BY EXTENDING THE SIDE PROPERTY LINES TO THE CURB.
5. DRIVEWAY SHALL NOT EXCEED 70 PERCENT OF A LOT STREET FRONTAGE.
6. THE TYPE I DRIVEWAYS ARE TO BE LOCATED NO CLOSER TO THE CORNER OF INTERSECTING RIGHTS OF WAY THAN 60 PERCENT OF PARCEL FRONTAGE OR 50 FEET; WHICHEVER IS LESS.
7. DRIVEWAYS SHALL NOT BE CONSTRUCTED WITHIN THE CURB RETURN OF A STREET INTERSECTION
8. SINGLE FAMILY LOTS LIMITED TO ONE DRIVEWAY EXCEPT FOR APPROVED SEMI-CIRCULAR DRIVES.
9. WHEN TWO DRIVEWAYS ARE USED (ONE PER UNIT; TWO MAXIMUM) FOR DUPLEXES AND TOWN HOMES, SINGLE FAMILY STANDARDS SHALL APPLY.
10. WHILE THE PROPERTY OWNER REMAINS RESPONSIBLE FOR GRADE BREAKS WITHIN PRIVATE PROPERTY, THE FIRE DEPARTMENT SHOULD BE CONSULTED WHERE THE DRIVEWAY IS ESSENTIAL TO EMERGENCY VEHICLE ACCESS AND 'G2' IS GREATER THAN 15% . 'G1' PLUS 'D' SHOULD NOT EXCEED 15% .
11. SEE TRANSPORTATION CRITERIA MANUAL SECTION 5 FOR OTHER DRIVEWAY REQUIREMENTS.
12. USE 1/2" ASPHALT BOARD, OR OTHER APPROVED MATERIAL, FOR CURB AND GUTTER EXPANSION JOINTS.

| | | | |
|---|-----------------|--|--------------|
| CITY OF AUSTIN DEPARTMENT OF PUBLIC WORKS AND TRANSPORTATION | | TYPE I DRIVEWAY (1 & 2 FAMILY RESIDENTIAL USE ONLY) | |
| <i>Luis Rivera</i> APPROVED | 7-15-97 DATE | ADOPTED: 11-22-95 | STANDARD NO. |
| | | SCALE: N.T.S. | 433-1 |
| | | INITIAL: H.D.T. | 2 OF 2 |